

SOFAS COLLECTION
VOLUME TWO

Poliform

Poliform

Per completare divani e poltrone, Poliform propone i complementi: tavolini dai volumi contemporanei, pouf eleganti e versatili, tappeti fatti a mano con materiali di pregio. Complementi nel significato più pieno del termine, oggetti che completano l'arredamento di ogni ambiente con stile ed eleganza: Poliform fin nei dettagli.

To complete sofas and armchairs, Poliform offers the complements: coffee tables with contemporary volumes, elegant and versatile poufs, hand-made rugs with quality materials. Complements in the truest meaning of the term, objects that complete the furniture of each environment with style and elegance: Poliform down to the details.

COLLECTIONS

TAVOLINI
COFFEE TABLES

7

POUF
POUFS

185

TAPPETI
CARPETS

251

COFFEE TABLES

Una collezione di proposte diverse per estetica e materiali. Classici o contemporanei, caratterizzati da forme organiche o geometriche, imponenti o compatti, realizzati in finiture laccate, essenza o metallo e impreziositi da piani in cuoio, marmo, onice e lapislazzuli. I tavolini Poliform sono delle micro-architetture che si adattano alle diverse zone della casa, accanto al divano in salotto o come comodini nella zona notte.

A collection of offers different in style and materials. Classic or contemporary, characterized by organic or geometric shapes, large or compact, made in lacquered finishes, wood, or metal, and embellished by tops in leather, marble, onyx, and lapis lazuli. Poliform coffee tables are micro-architectures that adapt to the different areas of the house, next to the sofa in the living room or as bedside tables in the night area.

COFFEE TABLES

CREEK	11
MONDRIAN	25
HENRY	41
BRISTOL	51
TRIBECA	61
HOME HOTEL	71
BIGGER	83
SOORI	93
ILDA	103
FLUTE	113
DAMA	123
BABA	133
PARIS SEOUL	143
SYDNEY	153
TRIDENTE	165
MAD COFFEE TABLES	175



CREEK

Creek è una collezione di tavolini di varie dimensioni, accomunati dal design composto da due vassoi sovrapposti appoggiati su una struttura di metallo. I colori e le finiture di ogni vassoio si possono abbinare a piacere, scegliendo tra colori laccati, legno, marmo e vetro per il vassoio superiore; colori laccati lucidi e opachi o legno per il vassoio inferiore.

Creek is a collection of coffee tables of various sizes, united by a design characterized by two trays on top of each other resting on a metal structure. The colours and finishes of each tray can be combined as desired, choosing between lacquered colours, wood, marble, and glass for the upper tray; glossy and mat lacquered colours or wood for the lower tray.



Qui e nella pagina precedente: tavolini Creek, quadrato con piano superiore in marmo sahara noir lucido, rettangolare con piano superiore in vetro fumé, piani inferiori in olmo nero e struttura brown nickel satinato. Tavolino Creek rotondo con piano superiore in marmo nero assoluto texture juta, piano inferiore in olmo nero e struttura brown nickel satinato. Divano Bellport rivestimento sfoderabile in pelle Nabuk 09 ruggine e piedini con profilo brown nickel opaco.

This and previous page: Creek coffee tables, square version with top in glossy marble sahara noir, rectangular version with top in fumé glass, lower shelves in black elm and structure in brushed brown nickel. Round coffee table Creek with top in marble nero assoluto texture juta, lower shelf in black elm and structure in brushed brown nickel. Bellport sofa with removable cover in leather Nabuk 09 ruggine and feet with profile mat brown nickel.



In questa pagina: tavolino Creek con piano superiore in vetro fumé, piano inferiore in olmo nero e struttura brown nickel satinato. Nella pagina successiva: tavolini Creek con piano superiore in marmo calacatta oro lucido, piano inferiore laccato lucido canapa e struttura champagne satinato.

This page: Creek coffee table with top shelf in fumé glass, lower shelf in black elm and mat brown nickel structure. Next page: Creek coffee tables with top shelf in glossy marble calacatta oro, canapa glossy lacquered lower shelf and structure in mat champagne.







In questa pagina: tavolino Creek con piano superiore in marmo lucido sahara noir finitura poliester, piano inferiore in olmo nero e struttura brown nickel satinato. Nella successiva: tavolini Creek, rettangolare e quadrato piani in marmo calacatta oro lucido e laccato lucido canapa, struttura champagne satinato; rotondi piani in vetro fumé e olmo nero, struttura in brown nickel satinato. Divani Bellport in tessuto sfoderabile Naxox 07 cemento, pouf Bellport in pelle sfoderabile Soft 13 carbone; divani e pouf con piedini champagne opaco. Poltrona Bellport con fondopiega in tessuto sfoderabile Kitami 09 senape e bordura in seta colore nero, piedini in brown nickel opaco. Tappeto Frame grey.

This page: Creek coffee table with top shelf in glossy marble sahara noir with polyester finish, lower shelf in black elm and mat brown nickel structure. Next page: Creek coffee tables, rectangular and square version with top in glossy marble calacatta oro and canapa glossy lacquer, structure in brushed metal champagne: round version with top in glass fumé and black elm, structure in brushed brown nickel metal. Bellport sofas with removable cover in fabric Naxos 07 cemento, pouf Bellport with removable cover in leather Soft 13 carbone; sofas and pouf with feet in mat champagne. Bellport armchair with removable slipcover in fabric Kitami 09 senape and border in silk colour nero, mat brown nickel feet. Carpet Frame grey.

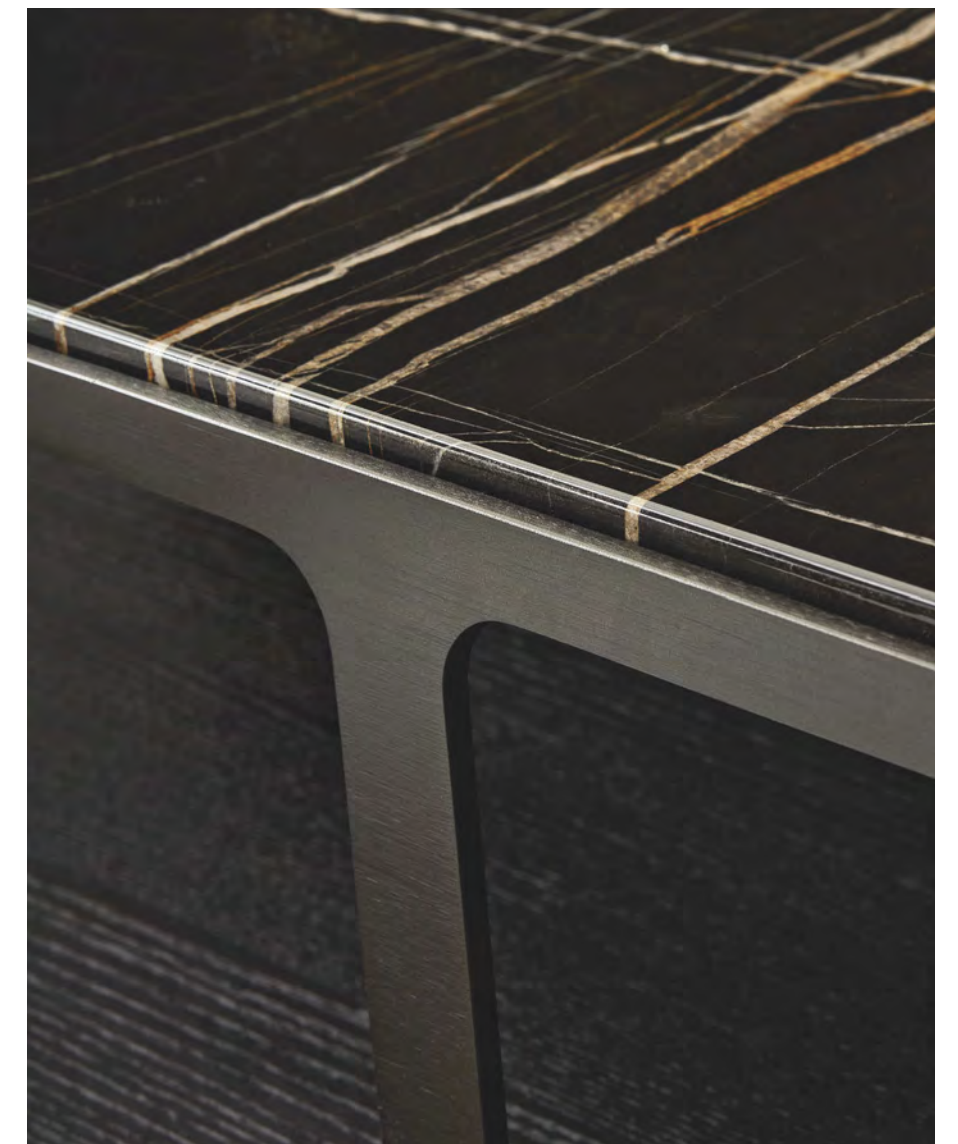



CREEK

Design Jean-Marie Massaud, 2018

Struttura in metallo brown nickel satinato o champagne satinato. Piano superiore in laccato opaco colori, laccato lucido colori, rovere spessart, olmo nero, vetro fumé 3050, cinque marmi levigati e sei lucidi o marmo nero assoluto texture juta.

Piano inferiore: laccato opaco colori, laccato lucido colori, rovere spessart o olmo nero.

Structure in brushed metal brown nickel or champagne. Top in mat lacquered colours, glossy lacquered colours, spessart oak, black elm, fumé glass 3050, five mat and six glossy marble finishes or marble nero assoluto texture juta. Lower shelf: mat lacquered colours, glossy lacquered colours, spessart oak or black elm.

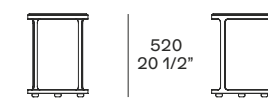
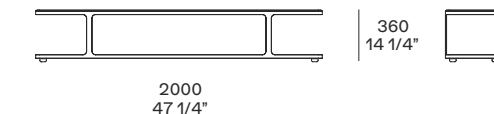
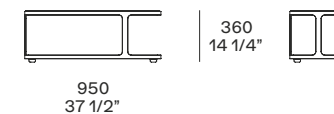
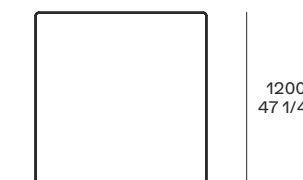
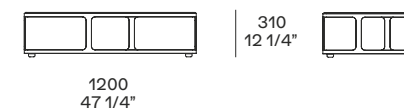

Ø 420
16 1/2"



MONDRIAN

Una collezione dall'immagine elegante e leggera, con sottili piani d'appoggio realizzati in essenza, marmo o nelle finiture laccato lucido e opaco. Disponibili in due altezze e di diverse forme per favorire la combinazione tra più elementi, questi tavolini sono facili da inserire nella zona living e perfetti in abbinamento all'omonimo sistema di divani.

A collection with an elegant and light image, with thin tops made of wood, marble, or glossy and mat lacquered finishes. Available in two heights and different shapes to facilitate the combination of several elements, these tables are easy to include in the living area and perfect in combination with the sofa system of the same name.



Nella pagina precedente: tavolini Mondrian con struttura in fusione di bronzo lucidata oro, piani in olmo nero e marmo calacatta oro levigato. Divano Mondrian rivestito in pelle sfoderabile Soft 10 prugna. In questa pagina: tavolini Mondrian con struttura in fusione di bronzo lucidata oro, piani in marmo noir saint laurent lucido e laccato lucido caramello. Divano Mondrian rivestito in tessuto sfoderabile Olimpia 11 polvere. Pouf Onda rivestimento non sfoderabile in pelle Soft 04 cognac. Tappeto Frame grey.

Previous page: Mondrian coffee tables with structure in gold polished bronze casting, top in black elm and mat marble calacatta oro. Mondrian sofa covered in non-removable leather Soft 10 prugna. This page: Mondrian coffee tables with structure in gold polished bronze casting, top in glossy marble noir saint Laurent and caramello glossy lacquer. Mondrian sofa covered in removable fabric Olimpia 11 polvere. Onda pouf covered in non-removable leather Soft 04 cognac. Carpet Frame grey.



In questa pagina: tavolino Mondrian con struttura in fusione di bronzo lucidata oro e piano in olmo nero. Nella successiva: consolle Mondrian con struttura in fusione di alluminio verniciato brown nickel lucido e piano in olmo nero. Tavolini Mondrian rotondi con struttura in fusione di alluminio verniciato brown nickel opaco e piani in laccato lucido muschio e olmo nero; rotondo piccolo con struttura in fusione di bronzo lucidata oro e piano in marmo noir saint laurent lucido; quadrato con struttura in fusione di alluminio verniciato brown nickel opaco e piano in marmo bianco carrara levigato.

This page: Mondrian coffee table with structure in gold polished bronze casting and black elm top. Next page: Mondrian console with structure in glossy brown nickel painted aluminium casting and top in black elm. Mondrian round coffee tables with structure in mat brown nickel painted aluminium casting, muschio glossy lacquered and black elm tops; round small version with structure in gold polished bronze casting and top in glossy marble noir saint laurent; square version with structure in mat brown nickel painted aluminium casting and top in mat marble bianco carrara.

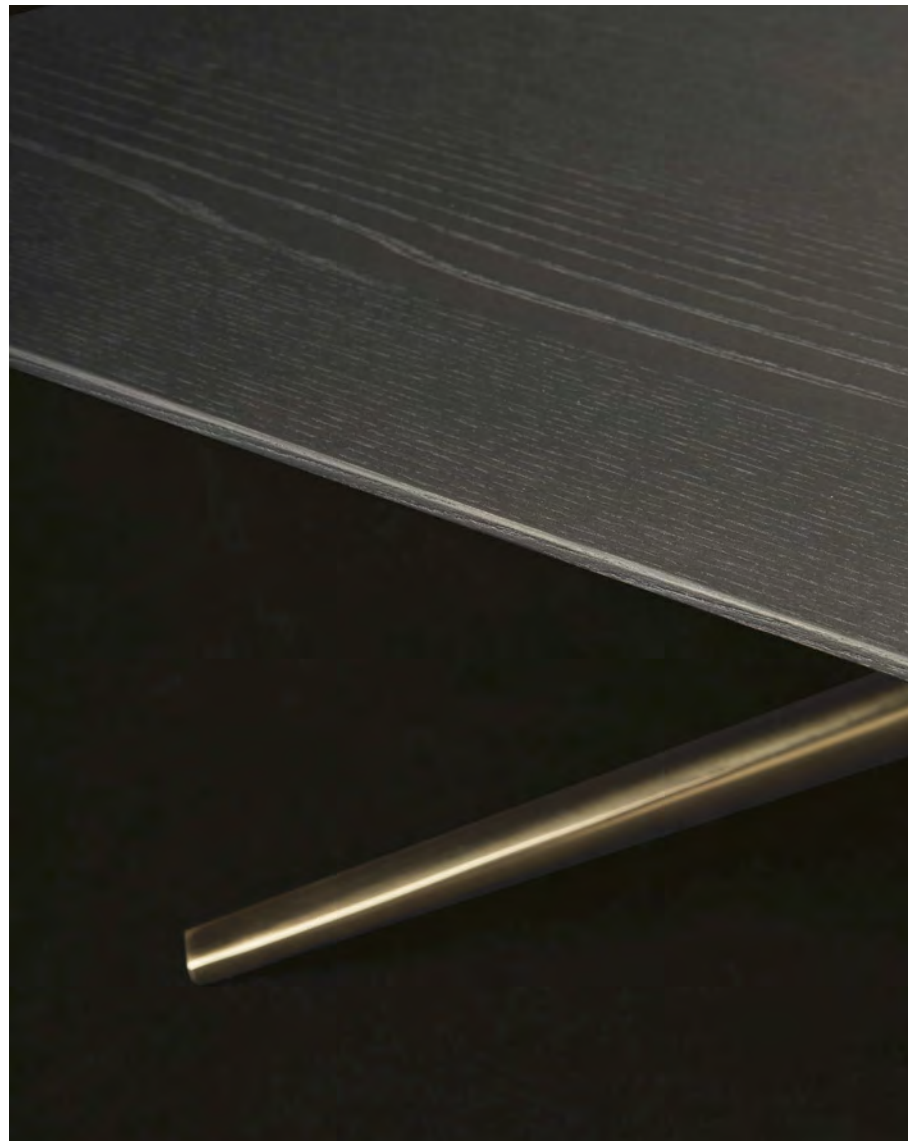



In questa pagina: tavolino Mondrian con struttura in fusione di alluminio verniciato brown nickel opaco e piano in marmo lucido sahara noir finitura poliester.

This page: Mondrian coffee table with structure in mat brown nickel painted aluminium casting and top in glossy marble sahara noir with polyester finish.





In questa pagina: tavolini e consolle Mondrian con struttura in fusione di bronzo lucidata oro e piani in marmo noir saint laurent lucido e laccato lucido muschio. Divano Mondrian in tessuto sfoderabile Sparta 18 panna. Pouf Play in pelle intrecciata non sfoderabile Nabuk 02 tortora. Tappeto Soft. Nella pagina successiva: tavolini Mondrian con struttura in brown nickel lucido e piani in olmo nero e laccato lucido ocra; con struttura in fusione di bronzo lucidata oro e piano in marmo calacatta oro levigato. Divano Mondrian in pelle sfoderabile Soft 10 prugna. Poltrone Marlon in tessuto sfoderabile Sparta 16 ferro, gambe in olmo nero.

This page: coffee tables and console Mondrian with structure in gold polished bronze casting and top in glossy marble noir saint laurent and glossy lacquered muschio. Mondrian sofa in removable fabric Sparta 18 panna. Carpet Soft. Next page: Mondrian coffee tables with structure in glossy brown nickel and tops in black elm and in ocra glossy lacquer; with structure in gold polished bronze casting and top in mat marble calacatta oro. Mondrian sofa in removable leather Soft 10 prugna. Marlon armchairs in removable fabric Sparta 16 ferro, legs in black elm.





MONDRIAN

Design Jean-Marie Massaud, 2016

Struttura in fusione di bronzo lucidata oro o in fusione di alluminio verniciato brown nickel opaco e lucido. Piano in laccato opaco colori, laccato lucido colori, rovere spessart, olmo nero o cinque marmi levigati e sei lucidi.

Structure in gold polished bronze casting or in mat and glossy brown nickel painted aluminium casting. Top in mat lacquered colours, glossy lacquered colours, spessart oak, black elm or in five mat and six glossy marble finishes.

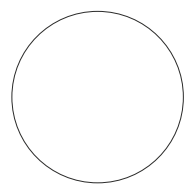
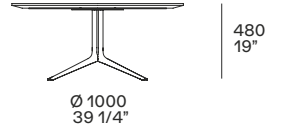
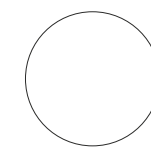
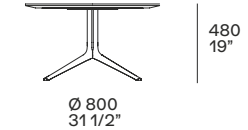
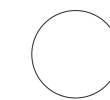
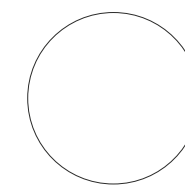
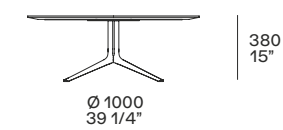
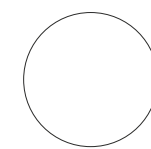
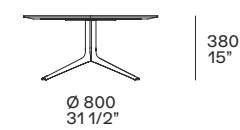
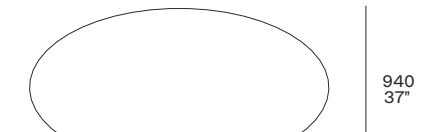
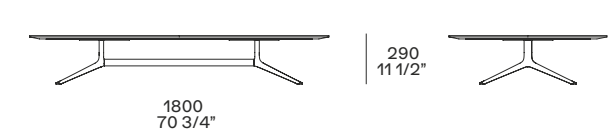
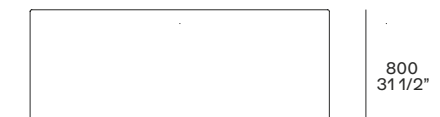
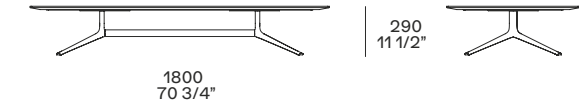
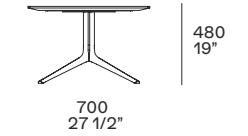
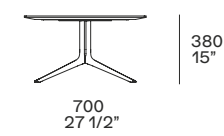

consolle altezza mm 480 / console height 19"

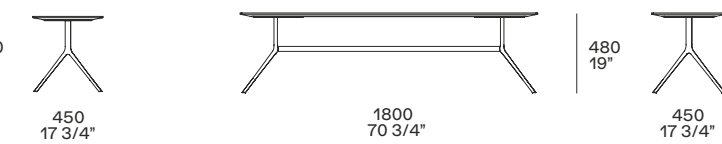
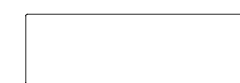
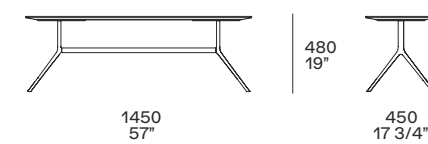

HENRY

Emmanuel Gallina disegna una collezione di tavolini dall'estetica lineare, con piano in marmo o vetro e struttura in essenza. Disponibili di varie forme e dimensioni, possono essere usati singolarmente o in combinazione.

Emmanuel Gallina designs a collection of coffee tables with a linear look, with a marble or glass top and a wooden structure. Available in various shapes and sizes, they can be used individually or in combination.



Nella pagina precedente: tavolino Henry con struttura in olmo nero e piano in vetro lucido bordeaux. Divano Jane rivestimento sfoderabile in tessuto Orleans 12 carbone e basamento in olmo nero. Tavolino Soori in metallo con finitura bronzo anticato. Tappeto Frame perla. In questa pagina: tavolino Henry con struttura in rovere spessart e piano in vetro lucido bordeaux.

Previous page: Henry coffee table with structure in black elm and top in glossy glass bordeaux. Jane sofa with removable cover in fabric Orleans 12 carbone and base in black elm. Soori coffee table in metal with antique bronze finish. Carpet Frame perla. This page: Henry coffee table with structure in spessart oak and top in glossy glass bordeaux.





In questa pagina: tavolini Henry con struttura in olmo nero, piani in vetro lucido arena e in marmo calacatta oro levigato. Nella pagina successiva: tavolino Henry con struttura in olmo nero e piano in vetro lucido bordeaux.

This page: Henry coffee tables with structure in black elm, top in glossy glass arena and in mat marble calacatta oro. Next page: Henry coffee table with structure in black elm and top in glossy glass bordeaux.





HENRY

Design Emmanuel Gallina, 2017

Struttura in massello, finitura in rovere spessart o olmo nero. Piano in cinque marmi levigati e sei lucidi o in vetro lucido nei colori 2273 ghiaccio, 1264 arena, 1204 grafite, 2259 bordeaux.

Structure in solid wood, spessart oak or black elm finish. Top in five mat and six glossy marble finishes or in glossy glass in the colours 2273 ghiaccio, 1264 arena, 1204 grafite, 2259 bordeaux.

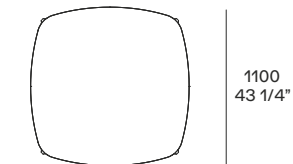
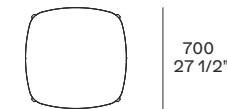
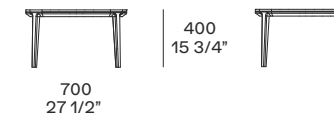
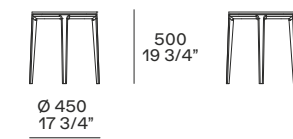
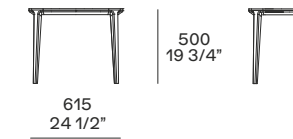
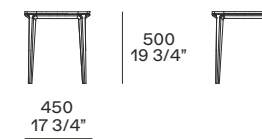



BRISTOL

A completare la collezione Bristol, composta da divano, libreria e madia, ci sono anche i tavolini da centro stanza, caratterizzati da due piani sovrapposti. Sostegni in metallo intersecano il piano superiore, diventando la cifra stilistica dell'intera collezione. Il piano inferiore è disponibile in laccato o in essenza, quello superiore anche in marmo.

To complete the Bristol collection, consisting of sofa, bookcase, and sideboard, there are also the centre coffee tables, characterized by two planes on top of each other. Metal supports intersect the upper top, becoming the signature style of the entire collection. The lower plane is available lacquered or in wood, the upper one also in marble.



Nella pagina precedente: tavolino Bristol con piano superiore in marmo calacatta oro levigato, piano inferiore in olmo nero, inserti e piedini in brown nickel opaco. Divano Bristol in tessuto sfoderabile Milos 05 cemento, cuscini velluto Persia 1404 carbone e tavolini retro divano Bristol in olmo nero. Tavolini Tribeca in brown nickel opaco e piani in olmo nero. Pouf Onda in pelle non sfoderabile Soft 04 cognac. Poltrone Mad Joker rivestimento non sfoderabile, esterno in pelle Nabuk 02 tortora e interno in tessuto Argo 1004 cenere, basamento girevole in brown nickel lucido. In questa pagina: tavolino Bristol con piano superiore in marmo noir saint laurent lucido, piano inferiore laccato lucido visone, inserti e piedini in brown nickel opaco.

Previous page: Bristol coffee table with top in mat marble calacatta oro, lower shelf in black elm, inlays and feet in mat brown nickel. Bristol sofa in removable fabric Milos 08 cemento, cushions in velvet Persia 1404 carbone and Bristol coffee tables to the back of the sofa in black elm. Tribeca coffee tables in mat brown nickel and top in black elm. Onda pouf in non-removable leather Soft 04 cognac. Mad Joker armchairs with non-removable cover, outer cover in leather Nabuk 02 tortora and inner cover in fabric Argo 1004 cenere, swivel base in glossy brown nickel. This page: Bristol coffee table with top in glossy marble noir saint Laurent, visone glossy lacquered lower shelf, inlays and feet in mat brown nickel.





In questa pagina: tavolino Bristol con piani in olmo nero, inserti e piedini in brown nickel lucido. Nella pagina successiva: tavolino Bristol con piano superiore in marmo calacatta oro levigato, piano inferiore in olmo nero, inserti e piedini in brown nickel opaco. Divano Bristol in tessuto sfoderabile Milos 05 cemento. Pouf Onda in pelle non sfoderabile Soft 04 cognac.

This page: Bristol coffee table with top and lower shelf in black elm, inlays and feet in glossy brown nickel. Next page: Bristol coffee table with top in mat marble calacatta oro, lower shelf in black elm, inlays and feet in mat brown nickel. Bristol sofa in removable fabric Milos 05 cemento. Onda pouf in non-removable leather Soft 04 cognac.





BRISTOL SYSTEM

Design Jean-Marie Massaud, 2014

Piani in laccato opaco colori, laccato lucido colori, rovere spessart o olmo nero.
 Piano superiore disponibile anche in marmo bianco carrara, calacatta oro e grigio stardust levigati e lucidi o in noir saint laurent lucido. Inserti e piedini in metallo verniciato brown nickel opaco o lucido.

Shelves in mat lacquered colours, glossy lacquered colours, spessart oak or black elm. Top shelf available also in mat and glossy marble bianco carrara, calacatta oro and grigio stardust or in glossy marble noir saint laurent. Inlays and feet in mat or glossy brown nickel painted metal.

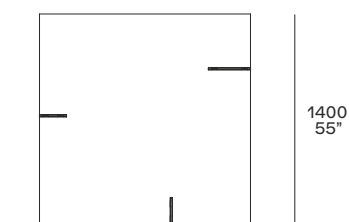
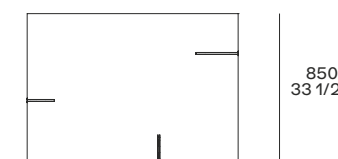
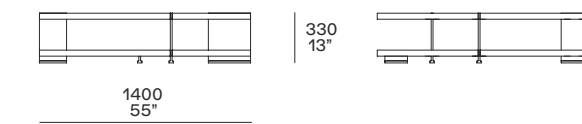
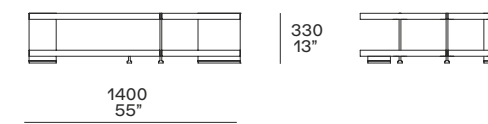



TRIBECA

Il living secondo Jean-Marie Massaud, che crea un sistema di divani e tavolini caratterizzati dalla base in metallo e dalla rigorosa geometria. I coffee table sono completati da piani in essenza o marmo, di dimensioni e forme diverse. L'insieme è di carattere e allo stesso tempo elegante, splendida unione per ambienti di classe.

The living area according to Jean-Marie Massaud, who creates a system of sofas and coffee tables characterized by a metal base and rigorous geometry. The coffee tables are completed by tops in wood or marble, of different sizes and shapes. The whole set has character but is elegant at the same time, splendid combination for classy environments.



Nella pagina precedente: tavolino Tribeca con struttura in brown nickel opaco e piano in marmo calacatta oro lucido. Composizione Wall System in rovere cenere, griglie interne sp 14 mm in laccato opaco piombo con ribalta sporgente Jet nella versione bar. Poltrona Santa Monica Home in tessuto sfoderabile Norway 19 prussia. Pouf Onda in velluto sfoderabile Persia 1403 ocra. In questa pagina: tavolino Tribeca rettangolare con struttura in brown nickel opaco e piano in olmo nero, rotondo con struttura in brown nickel lucido e piano in marmo noir saint laurent lucido.

Previous page: Tribeca coffee table with structure in mat brown nickel and top in glossy marble calacatta oro. Wall System bookcase in cenere oak with piombo mat lacquered partitions th 14 mm, jutting out flap door Jet in the version with bar accessories. Santa Monica Home armchair in removable fabric Norway 19 prussia. Onda pouf in removable velvet Persia 1403 ocra. This page: Tribeca rectangular coffee table with structure in mat brown nickel and top in black elm, round version with structure in glossy brown nickel and top in glossy marble noir saint laurent.





In questa pagina: tavolino Tribeca con struttura in brown nickel opaco e piano in marmo emperador dark levigato. Nella pagina successiva: tavolini Tribeca con struttura in brown nickel opaco e piani in marmo emperador dark lucido. Composizione Wall System con struttura, schienali e inserti attrezzati in rovere spessart, ante Slim a ribalta laccato opaco visone. Divano Paris Seoul in tessuto sfoderabile Merida 99 écreu, cuscini in velluto Persia 2006 prugna.

This page: Tribeca coffee table with structure in mat brown nickel and top in mat marble emperador dark. Next page: Tribeca coffee tables with structure in mat brown nickel and top in glossy marble emperador dark. Wall System bookcase with structure, backs and accessorized inserts in spessart oak, visone mat lacquered flap doors Slim. Paris Seoul sofa in removable fabric Merida 99 ecru, cushions in velvet Persia 2006 prugna.





TRIBECA

Design Jean-Marie Massaud, 2012

Struttura in metallo verniciato brown nickel opaco o lucido. Piano in rovere spessart, olmo nero o in cinque marmi levigati e sei lucidi.

Structure in mat or glossy brown nickel painted metal. Top in spessart oak, black elm or in five mat and six glossy marble finishes.

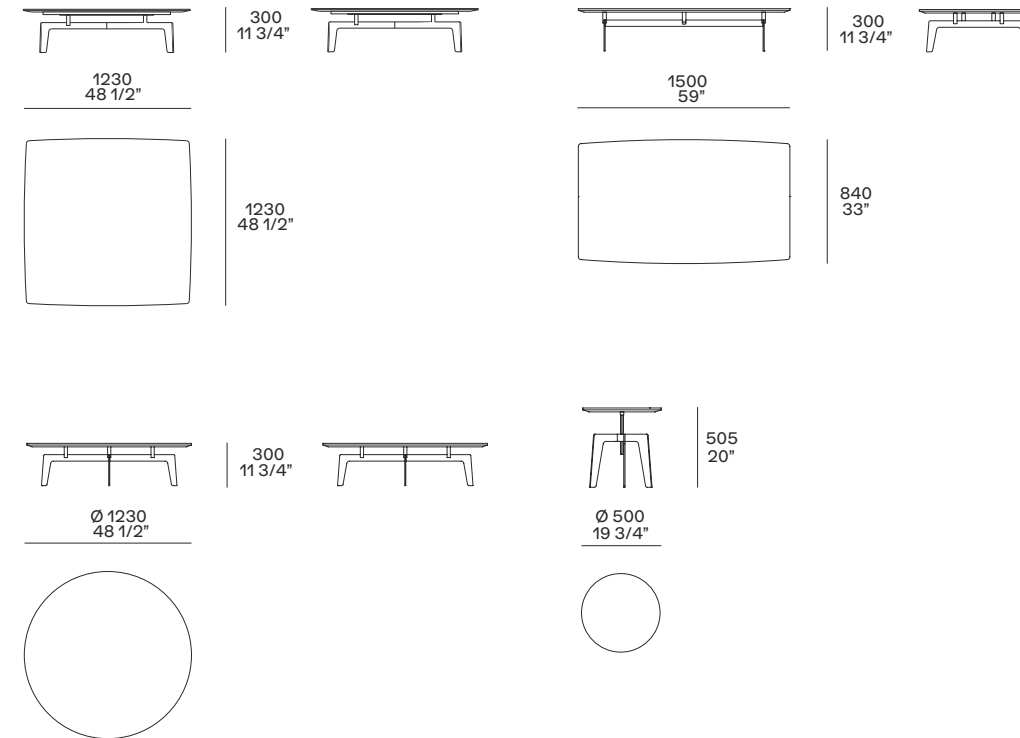



HOME HOTEL

Il filo conduttore dei tavolini Home Hotel è la versatilità. Le due versioni, rettangolare e quadrata, sono accomunate dal piano in essenza, che acquista ritmo grazie al particolare gioco di listelli. Assieme a consolle e panche, i tavolini Home Hotel creano un vero e proprio sistema, in casa e nei luoghi dell'ospitalità.

The theme of the Home Hotel coffee tables is versatility. The two versions, rectangular and square, share a wooden top that acquires rhythm thanks to the particular play of strips. Together with the console tables and benches, the Home Hotel coffee tables create a true system, for the house and for accommodation facilities.





Nella pagina precedente: tavolino Home Hotel in olmo nero. Divano Bristol in tessuto sfoderabile Naxos 17 corda con cuscini Zante 10 nero. Poltrona Jane in tessuto sfoderabile Persia 54 prussia e basamento in olmo nero. Tavolino Baba in metallo verniciato oro lucido e piano in vetro oro. Pouf Henry in olmo nero e seduta non sfoderabile in velluto Persia 1404 carbone. Tappeto Frame carbone. In questa pagina: tavolino Home Hotel in olmo nero. Divano Bristol in tessuto sfoderabile Kitami 02 cenere. Tavolino Dama laccato lucido muschio. Poltrone Ipanema in olmo nero e pelle non sfoderabile Nabuk 01 latte.

Previous page: Home Hotel coffee table in black elm. Bristol sofa in removable fabric Naxos 17 corda with cushions Zante 10 nero. Jane armchair in removable fabric Persia 54 prussia and base in black elm. Baba coffee table in glossy gold painted metal and top in gold glass. Henry pouf in black elm and seat in non-removable velvet Persia 1404 carbone. Carpet Frame carbone. This page: Home Hotel coffee table in black elm. Bristol sofa in removable fabric Kitami 02 cenere. Muschio glossy lacquered Dama coffee table. Ipanema armchairs in black elm and non-removable leather Nabuk 01 latte.



In questa pagina: tavolino Home Hotel con struttura e piano in olmo nero. Sotto: dettaglio della struttura e dei listelli che caratterizzano il piano della collezione tavolini e panche Home Hotel.

This page: Home Hotel coffee table with structure and top in black elm. Below: close up of the structure and of the wooden slats distinguishing the top of the coffee tables and benches collection Home Hotel.



In questa pagina: tavolino Home Hotel con struttura e piano in olmo nero. Nella pagina successiva: panca Home Hotel struttura e seduta a listelli in olmo nero con cuscino in pelle Nabuk 01 latte. Armadi Senzafine Fitted in vetro fumé con profili e maniglie laccato opaco carbone e armadi Senzafine Ocean in vetro satinato nero con profili verniciato opaco carbone. Tappeto Dama.

This page: Home Hotel coffee table with structure and top in black elm. Next page: Home Hotel bench, structure and seat with slats in black elm with cushion in leather Nabuk 01 latte. Wardrobes Senzafine Fitted in fumé glass with carbone mat lacquered profiles and handles and wardrobes Senzafine Ocean in frosted glass nero with carbone mat painted profiles. Carpet Dama.

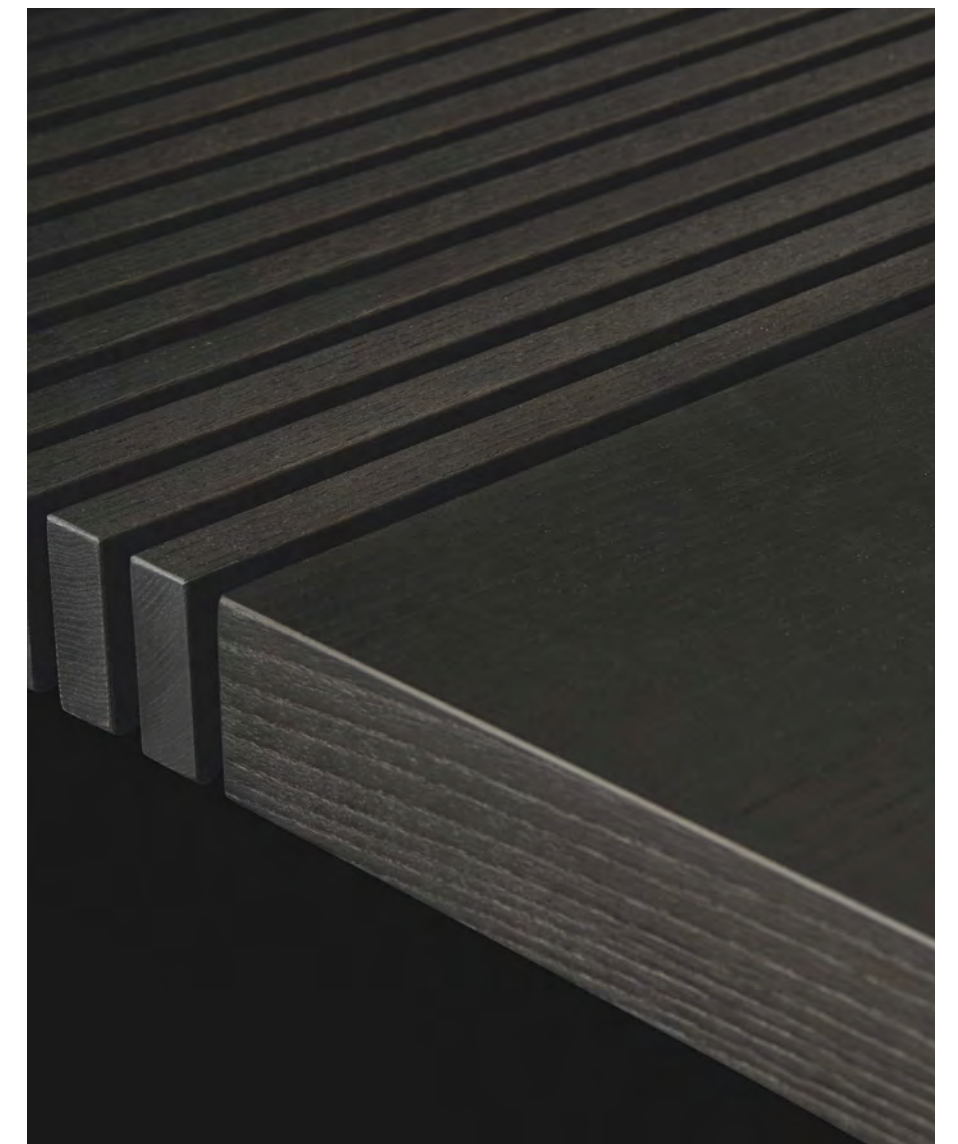



HOME HOTEL
Design Jean-Marie Massaud, 2017

Struttura e listelli piano in massello, finitura olmo nero. Piano in olmo nero.
Per panche cuscino opzionale con rivestimento sfoderabile in tessuto o pelle; nella versione pelle Nabuk possibilità pelle Nabuk intrecciata nella parte superiore.

Structure and slats of the top in solid wood finish black elm. Top in black elm. For the benches, optional cushion with removable cover in fabric or leather; in the version in Nabuk leather the upper part can have a woven manufacturing.

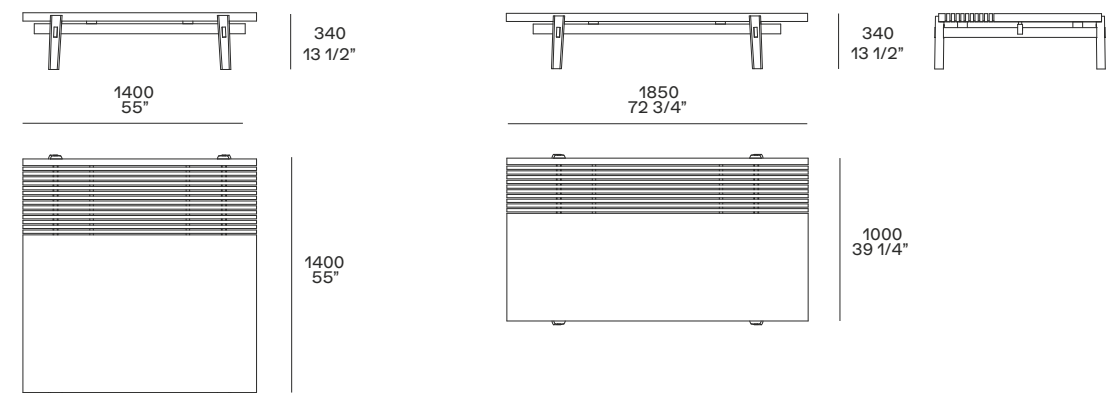

**Panche
Benches**

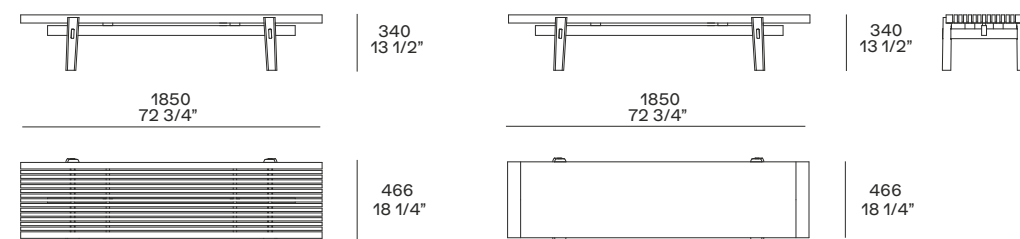

**Cuscino
Cushion**

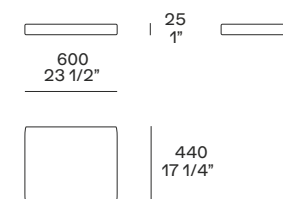



BIGGER

La collezione di tavolini disegnata da Carlo Colombo è caratterizzata dalla struttura in essenza e dai piani dagli angoli arrotondati in laccato lucido e opaco, oppure impreziositi dai marmi. Uno stile versatile, facile da inserire nella zona giorno come nella zona notte.

The collection of coffee tables designed by Carlo Colombo is characterized by the wooden structure and the tops with rounded corners in glossy and mat lacquer, or embellished with marble. A versatile style, easy to include both in the day area and the night area.



Nella pagina precedente: tavolino Bigger con struttura in rovere spessart e piano in laccato lucido granata. Divano Shangai con imbottitura in piuma, rivestimento sfoderabile in tessuto Hannover 14 grafite, cuscini Norway 06 sabbia. Pouf Elise con rivestimento sfoderabile in tessuto Rabat 412 cemento e cucitura a cordoncino nero. In questa pagina: tavolino Bigger con struttura in olmo nero e piano in laccato lucido visone.

Previous page: Bigger coffee table with structure in spessart oak and granata glossy lacquered top. Shangai sofa with feather padding, removable cover in fabric Hannover 14 grafite, cushions Norway 06 sabbia. Elise pouf with removable cover in fabric Rabat 412 cemento and drawstring stitching nero. This page: Bigger coffee table with structure in black elm and visone glossy lacquered top.





In questa pagina: tavolino Bigger con struttura in olmo nero e piano in marmo calacatta oro lucido. Nella pagina successiva: tavolino Bigger con struttura in rovere spessart e piano in marmo emperador dark lucido. Divano Paris Seoul rivestimento sfoderabile in tessuto Hannover 04 titanio, cuscini Hannover 14 grafite e Siviglia 45 prato. Libreria Wall System in rovere spessart.

This page: Bigger coffee table with structure in black elm and top in glossy marble calacatta oro. Next page: Bigger coffee table with structure in spessart oak and top in glossy marble emperador dark. Paris Seoul sofa with removable cover in fabric Hannover 04 titanio, cushions in Hannover 14 grafite and Siviglia 45 prato. Wall System bookcase in spessart oak.





BIGGER

Design Carlo Colombo, 2012

Struttura in massello, finitura in rovere spessart o olmo nero. Piano in laccato opaco colori, laccato lucido colori o in cinque marmi levigati e sei lucidi.

Structure in solid wood finish spessart oak or black elm. Top mat lacquered colours, glossy lacquered colours or in five mat and six glossy marble finishes.

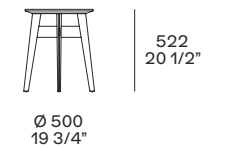
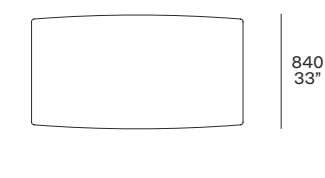
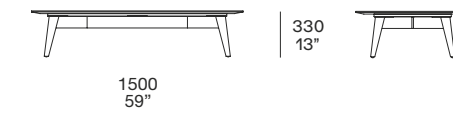
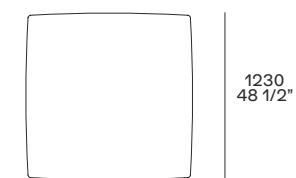

Piano in marmo Top in marble

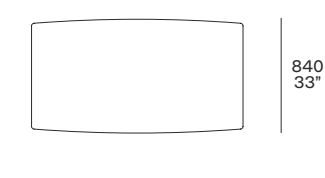
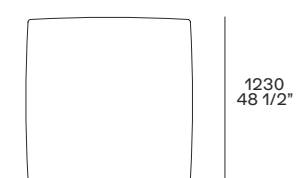

SOORI

Ispirato a Bali e alla sua cultura, e in particolare ai vasi tradizionali utilizzati nei villaggi di questa paradisiaca isola indonesiana, Soori è un tavolino dall'estetica originale e riconoscibile. Disegnato da Soo Chan, è disponibile in tre misure in metallo con finitura bronzo anticata e, nel caso del più piccolo, anche in laccato lucido e opaco.

Inspired by Bali and its culture, and in particular by the traditional vases used in the villages of this paradisiacal Indonesian island, Soori is a coffee table with an original and recognizable look. Designed by Soo Chan, it is available in three sizes in metal with antique bronze finish and, for the smaller one, also in glossy and mat lacquer.



Qui e nella pagina precedente: tavolino Soori in metallo finitura bronzo anticato. Poltrona Santa Monica rivestimento sfoderabile in pelle Nabuk 02 tortora.

This and next page: Soori coffee table in metal with antique bronze finish. Santa Monica armchair with removable cover in leather Nabuk 02 tortora.

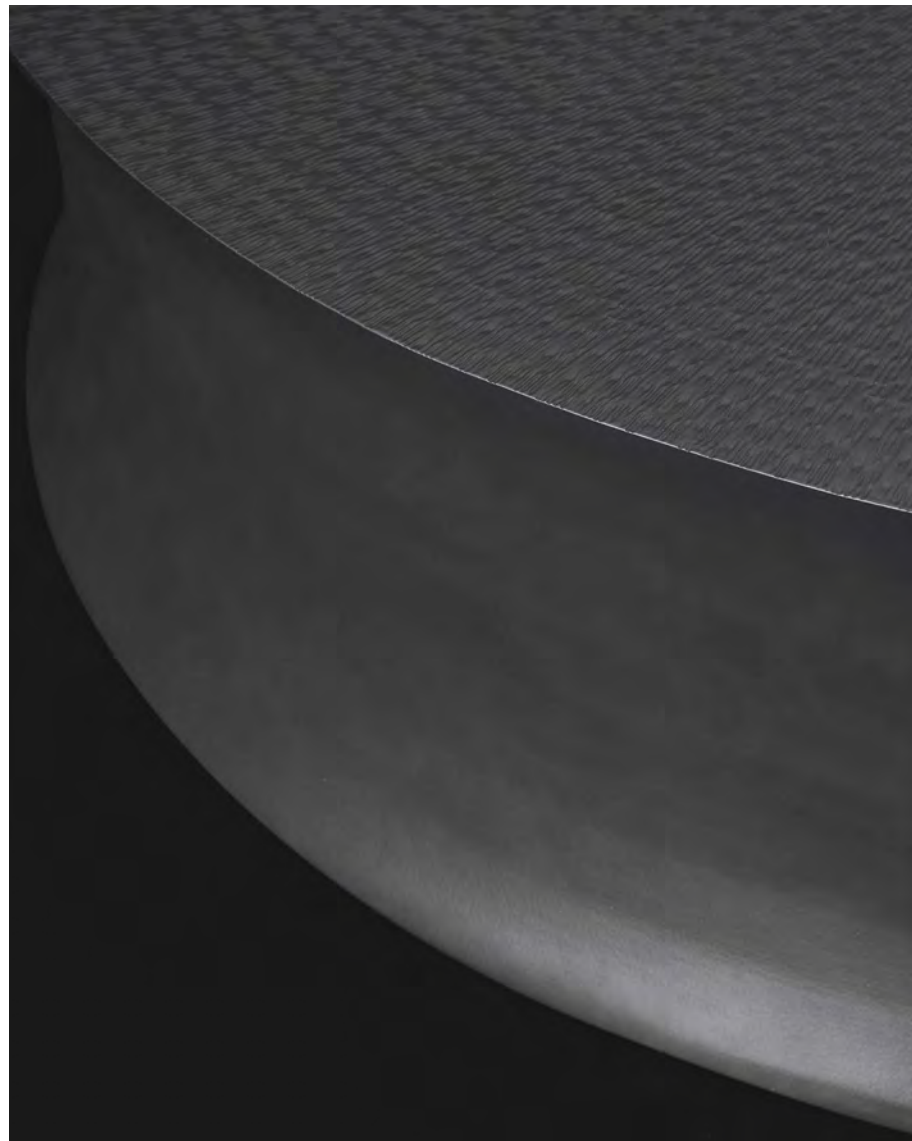



In questa pagina: tavolini Soori in metallo finitura bronzo anticato. Nella pagina successiva: tavolino Soori in metallo finitura bronzo anticato. Letto Rever, rivestimento in tessuto sfoderabile Orleans 05 pernice e pelle Nabuk 01 latte. Coordinato letto Provence 01 bianco e 08 polvere profilo nero. Panca Home Hotel in olmo nero.

This page: Soori coffee tables in metal with antique bronze finish. Next page: Soori coffee table in metal with antique bronze finish. Rever bed with cover in removable fabric Orleans 05 pernice and leather Nabuk 01 latte. Bed linen Provence 01 bianco and 08 polvere with profile nero. Home Hotel bench in black elm.





SOORI

Design Soo Chan, 2011

Struttura e piano in metallo finitura bronzo anticato. Il tavolino piccolo è disponibile anche in poliuretano laccato opaco colori o laccato lucido colori.

Structure and top in metal with antique bronze finish. The small coffee table is available also in mat lacquered and glossy lacquered polyurethane in the colours as per sample book.

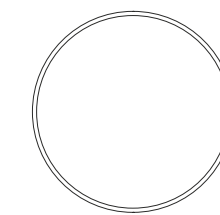
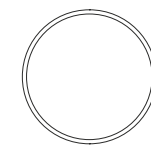
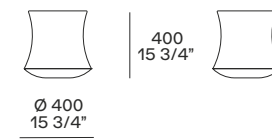



ILDA

I tavolini Ilda sono veri e propri gioielli perché la struttura portante è una fusione di ottone, lucidata oro o bronzata, forgiata in una fonderia artistica e rifinita a mano. I piani sono in marmo, onice ambra o lapislazzuli. Un progetto prezioso, di grande impatto visivo, firmato Jean-Marie Massaud.

Ilda coffee tables are true gems, as the supporting structure is a fusion of brass, polished with gold or bronze, forged in an artistic foundry, and finished by hand. The tops are in marble, amber onyx, or lapis lazuli. A precious project of great visual impact by Jean-Marie Massaud.



Nella pagina precedente: tavolino Ilda con struttura in fusione d'ottone bronzata e piano in lapislazzulo blu. Letto Dream con pannellatura a muro rivestita in tessuto sfoderabile Skyros 02 sabbia e giroletto in pelle sfoderabile Soft 02 mastice. In questa pagina: tavolini Ilda con struttura in fusione d'ottone lucidata oro e piano in marmo calacatta oro levigato.

Previous page: Ilda coffee table with structure in bronzed brass casting and top in blue lapis lazuli. Dream bed with wall panelling covered in removable fabric Skyros 02 sabbia and bedframe in removable leather Soft 02 mastice. This page: Ilda coffee tables with structure in gold polished brass casting and top in mat marble calacatta oro.





In questa pagina: tavolini Ilda, basso con struttura in fusione d'ottone lucidata oro e piano in onice ambra, alto con struttura in fusione d'ottone bronzata e piano in marmo noir saint laurent lucido. Nella pagina successiva: tavolini Ilda con struttura in fusione d'ottone bronzata e piano in lapislazzulo blu. Poltrona Santa Monica rivestimento sfoderabile in pelle Nabuk 02 tortora.

This page: Ilda coffee tables, low version with structure in gold polished brass casting and top in glossy marble noir saint laurent. Next page: Ilda coffee tables with structure in bronzed brass casting and top in blue lapis lazuli. Santa Monica armchair with removable cover in leather Nabuk 02 tortora.





ILDA

Design Jean-Marie Massaud, 2017

Struttura in fusione di ottone, finiture bronzato o lucidato oro. Piano in onice ambra, lapislazzulo blu o in cinque marmi levigati e sei lucidi.

Structure in brass casting in bronzed or gold polished finish. Top in onyx amber, blue lapis lazuli or in five mat and six glossy marble finishes.

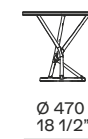

410
16 1/4"



Ø 470
18 1/2"



530
20 3/4"



Ø 390
15 1/4"





FLUTE

Come il tavolo Flute, anche il tavolino è un omaggio di Roberto Barbieri a forme sottili e pulite. Per la sua semplicità, unita a numerosi colori e finiture disponibili, si inserisce con eleganza in ogni contesto, accanto al divano o come comodino nella zona notte.

Like the Flute table, the coffee table too is a tribute by Roberto Barbieri to thin and clean shapes. Because of its simplicity, combined with the many available colours and finishes, it fits elegantly into any context, next to the sofa or as a bedside table in the night area.



Nella pagina precedente: tavolino Flute in laccato lucido granata. Divano Shangai con imbottitura in piuma, rivestimento sfoderabile in tessuto Hannover 14 grafite, cuscini Norway 06 sabbia. In questa pagina: tavolini Flute in laccato lucido canapa e piano tavolino basso in marmo calacatta oro levigato.

Previous page: granata glossy lacquered Flute coffee table. Shangai sofa with feather padding, removable cover in fabric Hannover 14 grafite, cushions Norway 06 sabbia. This page: canapa glossy lacquered Flute coffee tables, top of the low coffee table in mat marble calacatta oro.

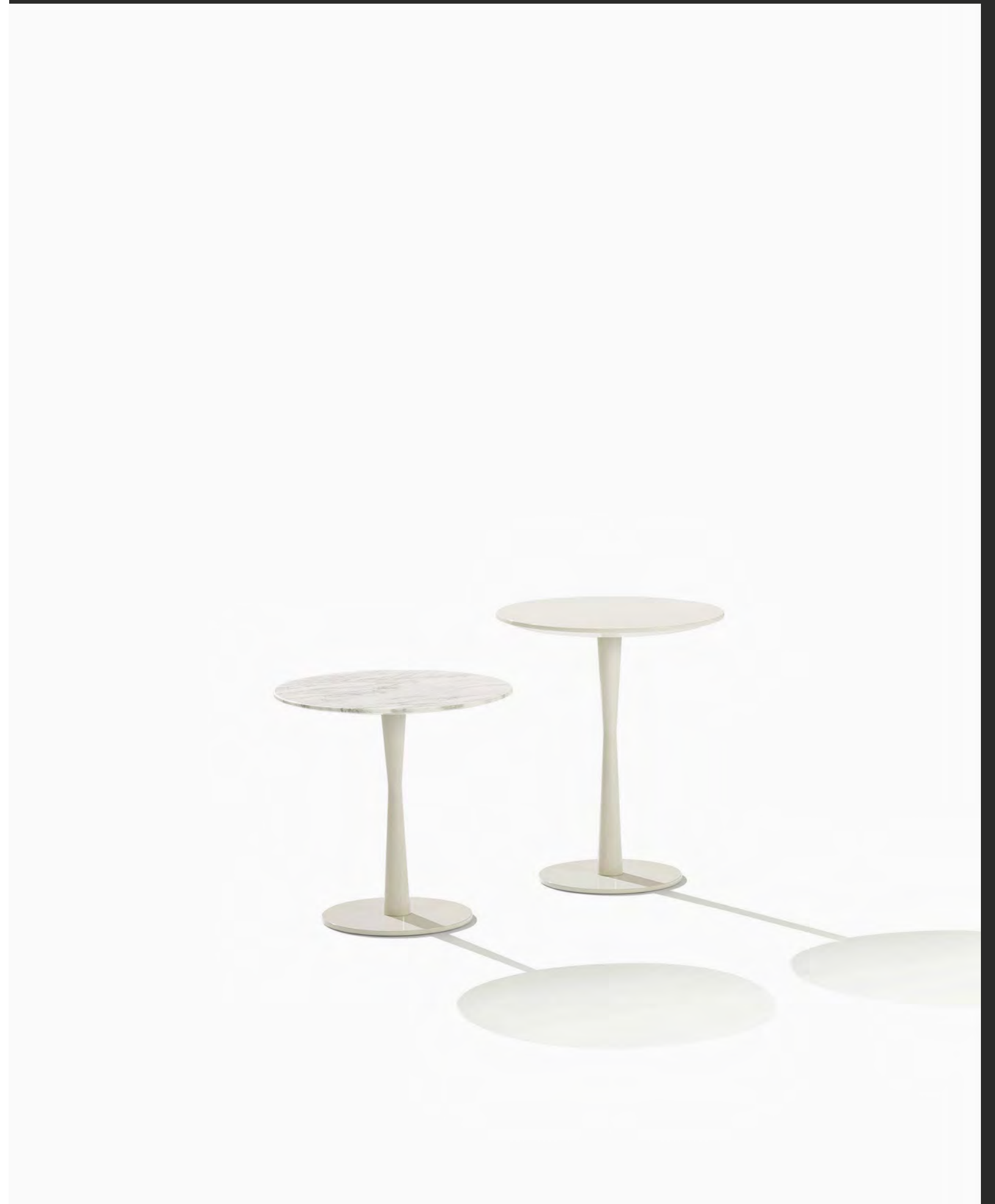



In questa pagina: tavolino Flute alto base in cromo nero e piano in vetro riflettente blu, Flute basso base in brown nickel opaco e piano in marmo noir saint laurent lucido. Nella pagina successiva: tavolino Flute base in laccato opaco nero e piano in marmo emperador dark lucido. Pouf Play rivestito in velluto sfoderabile Persia 1403 ocra. Letto Jacqueline in tessuto sfoderabile Lima 43 écreu, cucitura a cordoncino colore acciaio.

This page: high Flute coffee table with base in black chrome and top in blu reflecting glass, low Flute coffee table with base in mat brown nickel and top in glossy marble noir saint laurent. Next page: Flute coffee table with carbone mat lacquered base and top in glossy marble emperador dark. Play pouf covered in removable velvet Persia 1403 ocra. Jacqueline bed in removable fabric Lima 43 ecru, drawstring stitching acciaio.





FLUTE

Roberto Barbieri, 2008

Base in laccato opaco colori, laccato lucido colori, nella finitura antigraffio in bianco 01, carbone 91, grafite 04, canapa 35, verniciato brown nickel opaco e lucido o cromo nero. Piano in laccato opaco colori, laccato lucido colori, nella finitura antigraffio in bianco 01, carbone 91, grafite 04, canapa 35, cinque marmi levigati e sei lucidi o in vetro riflettente blu.

Base mat lacquered colours, glossy lacquered colours, anti-scratch finish in bianco 01, carbone 91, grafite 04, canapa 35, painted mat and glossy brown nickel or black chrome. Top mat lacquered colours, glossy lacquered colours, anti-scratch finish in bianco 01, carbone 91, grafite 04, canapa 35, five mat and six glossy marble finishes or blu reflecting glass.

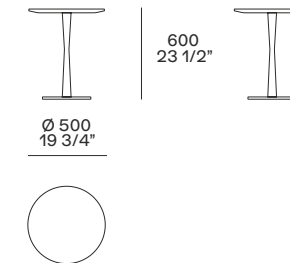
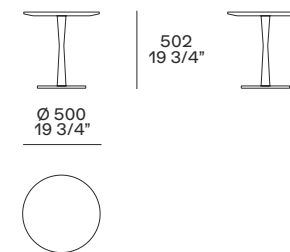



DAMA

Dama è un tavolino dall'estetica essenziale e riconoscibile: caldo e familiare nella versione in cedro o noce canaletto, diventa monolitico e contemporaneo nella versione laccata lucida o opaca.

Dama is a coffee table with a minimalistic and recognizable look: warm and familiar in the cedar or walnut version, it becomes monolithic and contemporary in the glossy or mat lacquered version.



Nella pagina precedente: tavolino Dama in massello noce canaletto. Poltrona Mad Joker e pouf Mad rivestimento non sfoderabile, esterno in pelle Soft 14 oliva e interno in tessuto Zante 07 oliva, basamento girevole in brown nickel lucido. In questa pagina: tavolini Dama nella versione massello di cedro e noce canaletto.

Previous page: Dama coffee table in solid walnut Canaletto. Mad Joker armchair and Mad pouf with non-removable cover, outer cover in leather Soft 14 oliva and inner cover in fabric Zante 07 oliva, swivel base in glossy brown nickel. This page: Dama coffee tables in the version solid cedar and walnut canaletto.





In questa pagina: tavolini Dama nella versione laccata, lucido nei colori arena, canapa e granata, opaco nel colore roccia. Nella pagina successiva: tavolino Dama in laccato lucido canapa. Poltrona Mad Chair rivestimento sfoderabile in pelle Cashmere bianco e gambe in olmo nero. Sistema giorno Quid, bacheche in olmo nero e ripiani in laccato opaco moka. Tappeto Frame gold.

This page: Dama coffee tables in the lacquered version, glossy colours arena, canapa and granata, mat colour roccia. Next page: canapa glossy lacquered Dama coffee table. Mad Chair armchair with removable cover in leather Cashmere bianco and legs in black elm. Day system Quid, open display cases in black elm and moka mat lacquered shelves. Carpet Frame gold.





DAMA

R&D Poliform, 2005

Tavolino in massello di cedro e noce canaletto o in poliuretano stampato nella finitura laccato opaco colori o laccato lucido colori.

Coffee table in solid cedar and walnut canaletto or in moulded polyurethane in the finish mat lacquered colours or glossy lacquered colours.

Versione massello **Version in solid wood**



Ø 320 - 340
12 1/2" - 13 1/2"



Versione laccato **Version in lacquer**

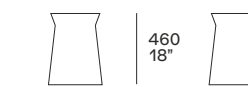

Ø 360 - 380
14 1/4" - 15"





BABA

Baba è un servetto che completa ogni situazione con stile ed eleganza. Versatile e informale, è caratterizzato da una struttura in metallo verniciato o laccato opaco e dal piano d'appoggio in marmo, vetro e in tutti i colori della gamma laccato opaco o lucido.

Baba is a side table that completes every situation with style and elegance. Versatile and informal, it is characterized by a painted or mat lacquered metal structure and by a top in marble, glass, and in all the colours of the mat or glossy lacquered range.



Nella pagina precedente: tavolino Baba in brown nickel opaco e piano in marmo emperador dark lucido. Pouf e divano Tribeca rivestimento in tessuto sfoderabile Oxford 11 sabbia. Sistema a giorno Wall System in rovere cenere, vetrine sporgenti Ghost in vetro trasparente riflettente con telaio verniciato ardesia e schienali laccato opaco caramello. Poltrone Santa Monica Home rivestimento sfoderabile in tessuto Norway 19 prussia. In questa pagina: tavolino Baba con struttura in metallo verniciato brown nickel opaco e piano in marmo grigio stardust levigato.

Previous page: Baba coffee table in mat brown nickel and top in glossy marble emperador dark. Pouf and sofa Tribeca with cover in removable fabric Oxford 11 sabbia. Day system Wall System in cenere oak, jutting out showcases Ghost in transparent reflecting glass with ardesia painted frame and caramello mat lacquered backs. Santa Monica Home armchairs with removable cover in fabric Norway 19 prussia. This page: Baba coffee table with structure in mat brown nickel painted metal and top in mat marble grigio stardust.





In questa pagina: tavolino Baba con struttura in metallo verniciato oro lucido e piano in vetro oro. Sotto: dettaglio dei piani in marmo noir saint laurent lucido e in vetro oro. Nella pagina successiva: tavolino Baba con struttura in metallo verniciato oro lucido e piano in vetro oro. Divano Bristol rivestito in tessuto sfoderabile Naxos 17 corda. Tappeto Frame carbone.

This page: Baba coffee table with structure in glossy gold painted metal and top in gold glass. Below: close up of the tops in glossy marble noir saint laurent and in gold glass. Next page: Baba coffee table with structure in glossy gold painted metal and gold glass top. Sofa Bristol covered in removable fabric Naxos 17 corda. Carpet Frame carbone.





BABA

Design Roberto Barbieri, 2012

Struttura in metallo verniciato brown nickel opaco e lucido, oro lucido, laccato opaco bianco o laccato opaco colori.
Piano laccato opaco colori, laccato lucido colori, cinque marmi levigati e sei lucidi o vetro oro.

Structure in painted metal mat and glossy brown nickel, glossy gold, mat lacquered bianco or mat lacquered colours.
Top mat lacquered colours, glossy lacquered colours, five mat and six glossy marble finishes or gold glass.

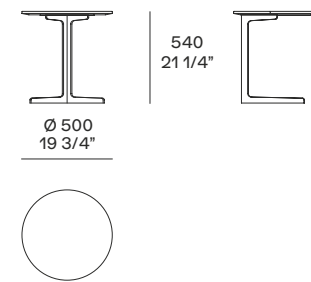

PARIS SEOUL

Della collezione Paris Seoul, progettata da Jean-Marie Massaud, fa parte anche il tavolino. Con struttura in metallo e rivestimento esterno in cuoio, si avvicina a divani e poltrone per tenere a portata di mano quanto serve.

This coffee table is also part of the Paris Seoul collection, designed by Jean-Marie Massaud. With metal structure and external leather covering, it stand next to sofas and armchairs to keep everything you need at your fingertips.



Nella pagina precedente: tavolino Paris Seoul in cuoio 02 nero e interno struttura in brown nickel lucido. Divano Bellport rivestimento sfoderabile in tessuto Naxos 07 cemento, cuscini in tessuto Sendai 03 fango e velluto Persia 1404 carbone, piedini champagne opaco. Sistema a giorno Wall System in rovere spessart, schienali laccato lucido canapa e luce led integrata. Tavolino Dama in laccato lucido granata. Tavolino Creek piani in marmo calacatta oro lucido e laccato lucido canapa, struttura champagne satinato. Tappeto Frame grey. In questa pagina: tavolino Paris Seoul in cuoio 02 nero e interno struttura in brown nickel lucido.

Previous page: Paris Seoul coffee table with outer cover in hide 02 nero and inner finish glossy brown nickel. Bellport sofas with removable cover in fabric Naxos 07 cemento, cushions in fabric Sendai 03 fango and velvet Persia 1404 carbone, feet in mat champagne. Wall System in spessart oak, canapa glossy lacquered backs and integrated led light. Granata glossy lacquered Dama coffee table. Creek coffee table with top in glossy marble calacatta oro and canapa glossy lacquer, structure in brushed metal champagne. Carpet Frame grey. This page: Paris Seoul coffee table with outer cover in hide 02 nero and inner finish glossy brown nickel.





Qui e nella pagina successiva: tavolino Paris Seoul in cuoio 26 invecchiato e interno struttura in brown nickel lucido. Divano Mondrian con poggiatesta, rivestito in tessuto sfoderabile Zante 12 corda, schienale in legno con mensole in olmo nero e piedini brown nickel lucido. Tappeto Plain tortora.

This and next page: Paris Seoul coffee table with outer cover in hide 26 invecchiato and inner finish in glossy brown nickel. Mondrian sofa with headrest cushion covered in removable fabric Zante 12 corda, back in wood with shelves in black elm and glossy brown nickel feet. Carpet Plain tortora.





PARIS SEOUL

Design Jean-Marie Massaud, 2012

Struttura in metallo, all'interno verniciato brown nickel opaco o lucido, all'esterno rivestito in cuoio colori.

Structure in metal, inner finish mat or glossy brown nickel painted metal, outer cover in hide in the available colours.

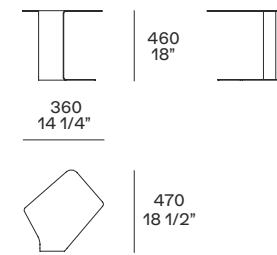



SYDNEY

Riprendono le forme geometriche dell'omonima collezione di divani i tavolini Sydney, disegnati da Jean-Marie Massaud. Due le versioni, servetto e tavolino; molte le finiture disponibili, dal marmo all'essenza, così come i colori, da scegliere nella gamma dei laccati opachi e lucidi.

The Sydney coffee tables, designed by Jean-Marie Massaud, reference the geometric shapes of the homonymous sofa collection. Two versions, side and coffee table; many finishes available, from marble to wood, as well as colours, to choose from the range of mat and glossy lacquers.





Qui e nella pagina precedente: tavolini Sydney con struttura e piano in olmo nero e in marmo noir saint laurent lucido. Divano Sydney in tessuto sfoderabile Lima 43 écreu con cuciture sahara, cuscini in tessuto Skyros 09 oliva e piedini brown nickel lucido. Panca Home Hotel in olmo nero. Sistema giorno Wall System in laccato opaco canapa, schienali in rovere spessart e schienali inclinati in gress porcellanato sahara noir con illuminazione a led integrata. Tappeto Plain natural.

This and previous page: Sydney coffee tables with structure and top in black elm and in glossy marble noir saint laurent. Sydney sofa in removable fabric Lima 43 ecru with stitching sahara, cushions in fabric Skyros 09 oliva and glossy brown nickel feet. Home Hotel bench in black elm. Day system Wall System in lacquered mat hemp, backs in spessart oak and oblique backs in porcelain stoneware sahara noir with integrated led lighting. Carpet Plain natural.



In questa pagina: tavolino Sydney con struttura e piano in laccato lucido granata. Sotto: dettaglio della particolarità del piano stondato.

This page: Sydney coffee table with structure and top glossy lacquered granata. Below: close up of the distinguishing rounded top.

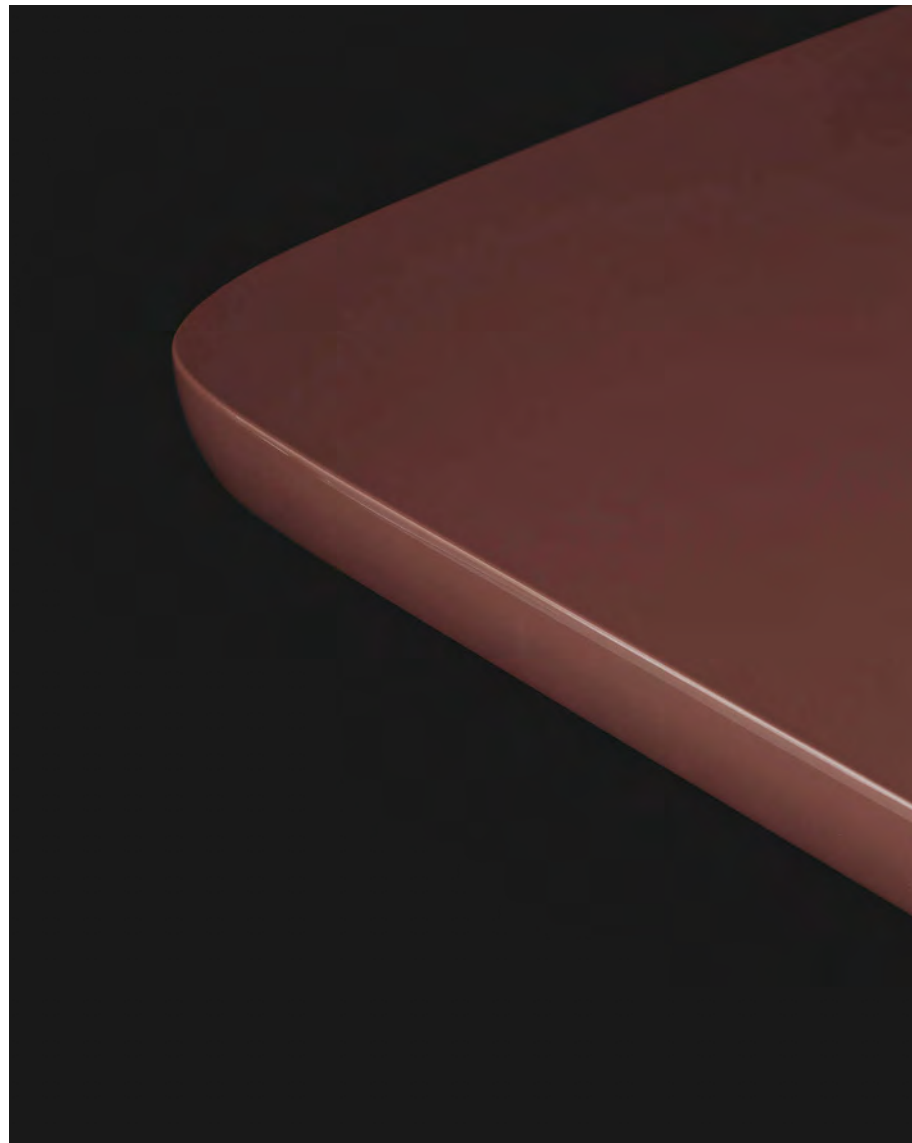



In questa pagina: tavolini Sydney con struttura e piano in marmo bianco carrara levigato e in laccato lucido granata. Nella pagina successiva: tavolini Sydney con struttura e piano in olmo nero e in marmo noir saint laurent lucido. Divano Sydney in tessuto sfoderabile Lima 43 é cru con cuciture sahara, cuscini in tessuto Skyros 09 oliva e piedini brown nickel lucido. Tappeto Plain natural.

This page: Sydney coffee tables with structure and top in mat marble bianco carrara and glossy lacquered granata. Next page: Sydney coffee tables with structure and top in black elm and in glossy marble noir saint laurent. Sydney sofa in removable fabric Lima 43 ecru with stitching sahara, cushions in fabric Skyros 09 oliva and glossy brown nickel feet. Carpet Plain natural.





SYDNEY

Design Jean-Marie Massaud, 2017

Struttura e piano in laccato opaco colori, laccato lucido colori o olmo nero. Il tavolino larghezza 1375 mm è disponibile anche con struttura e piano in marmo bianco carrara, grigio stardust e calacatta oro levigati e lucidi o in marmo saint laurent lucido.

Structure and top in mat lacquered colours, glossy lacquered colours or black elm. The coffee table width 1375 mm is available also with structure and top in marble bianco carrara, grigio stardust and calacatta oro in mat and glossy finish or in glossy marble noir saint laurent.

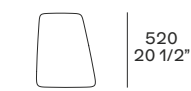
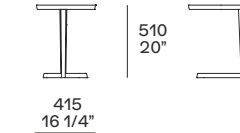
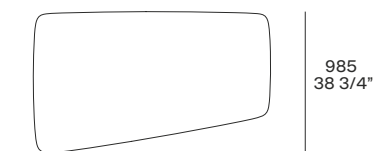
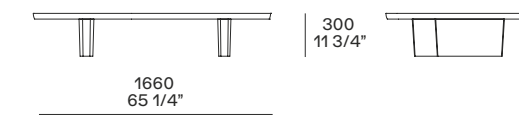
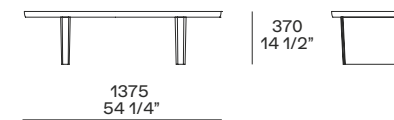
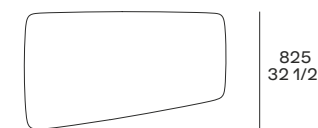
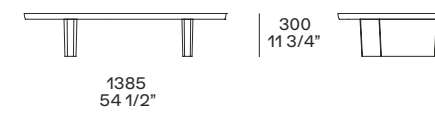



TRIDENTE

Nei tavolini Tridente, Emmanuel Gallina applica una lavorazione tradizionale del legno a una forma moderna, con struttura a T e cornice del piano in essenza. Il top, in due diverse configurazioni, può esaltare il legno o abbinarlo con eleganza a vetro lucido o marmo. Un tavolino che assolve una varietà di utilizzi, declinato in tre diverse altezze, anche da combinare tra loro.

In the Tridente coffee tables, Emmanuel Gallina applies traditional woodworking to a modern shape, with a T-shaped structure and frame of the top in wood. The top, in two different configurations, can enhance the wood or combine it elegantly with polished glass or marble. A table that has a variety of uses, available in three different heights, also to match one another.



Nella pagina precedente: tavolino Tribeca in olmo nero e piano in marmo noir saint laurent lucido. Divano e poltrone Jane in tessuto sfoderabile Skyros 2 oliva, basamento in brown nickel lucido. Pouf Gant in pelle non sfoderabile Soft 14 oliva. Madia Quid in laccato lucido canapa con top in marmo lucido calacatta oro e profilo maniglie in brown nickel lucido. In questa pagina: tavolino Tribeca in rovere spessart e piano in vetro lucido bordeaux. Sotto: dettaglio del piano in vetro lucido bordeaux caratterizzato dalla cornice in rovere spessart come la struttura.

Previous page: Tribeca coffee table in black elm and top in glossy marble noir saint laurent. Sofa and armchairs Jane in removable fabric Skyros 2 oliva, glossy brown nickel base. Gant pouf in non-removable leather Soft 14 oliva. Canapa glossy lacquered Quid sideboard with top in glossy marble calacatta oro, handle profile in glossy brown nickel. This page: Tribeca coffee table in spessart oak and top in glossy glass bordeaux. Below: close up of the top in glossy glass bordeaux with the distinguishing frame in spessart oak, same as the structure.





In questa pagina: tavolini Tribeca in olmo nero con piani in marmo grigio stardust lucido e in olmo nero. Nella pagina successiva: tavolino Tribeca in olmo nero e piano in marmo noir saint laurent lucido. Divano e poltrone Jane in tessuto sfoderabile Skyros 2 oliva, basamento in brown nickel lucido. Madia Quid in laccato lucido canapa con top in marmo lucido calacatta oro e profilo maniglie in brown nickel lucido.

This page: Tribeca coffee tables in black elm with top in glossy marble grigio stardust and in black elm. Next page: Tribeca coffee table in black elm and top in glossy marble noir saint laurent. Sofa and arm-chairs Jane in removable fabric Skyros 2 oliva, glossy brown nickel base. Canapa glossy lacquered Quid sideboard with top in glossy marble calacatta oro and glossy brown nickel handle profile.

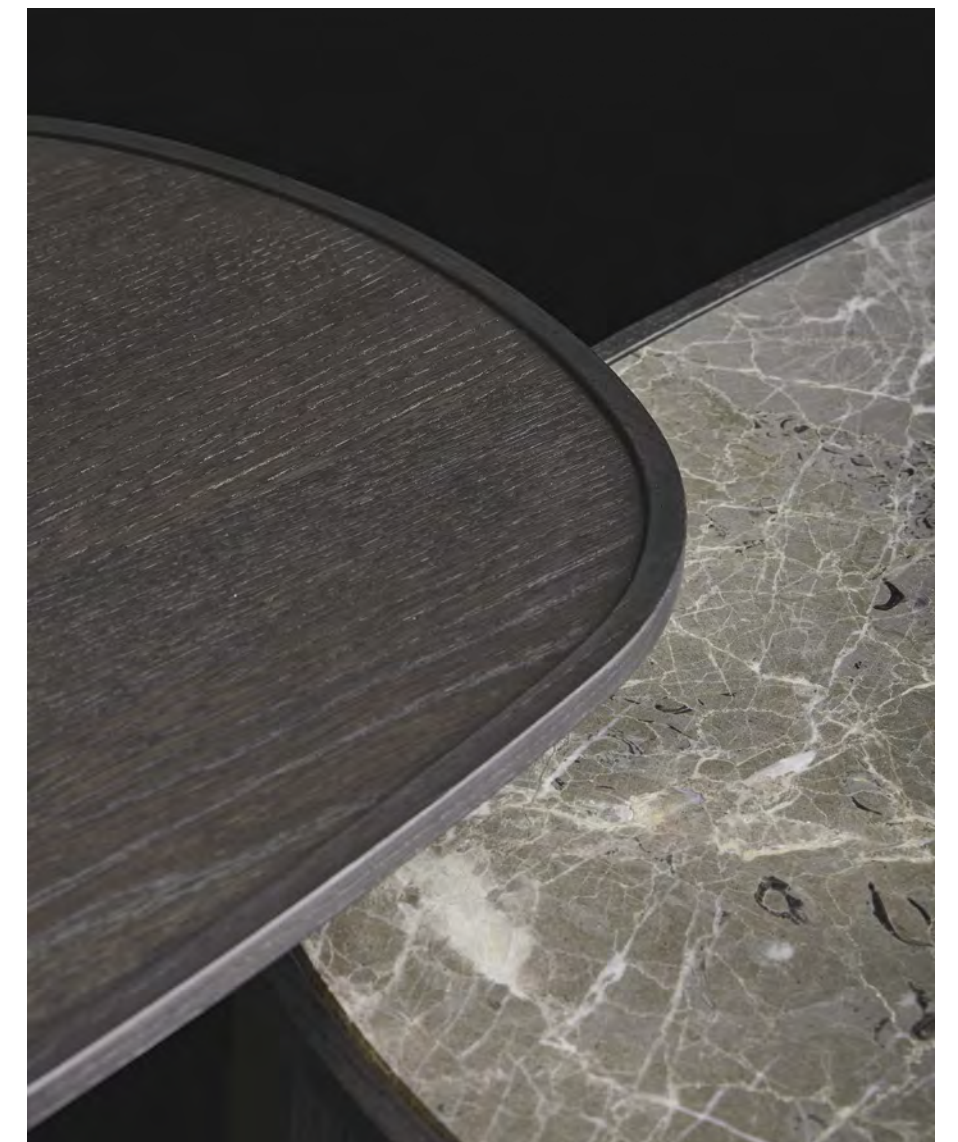



TRIDENTE

Design Emmanuel Gallina, 2007

Struttura e cornice piano in massello, finitura rovere spessart o olmo nero. Inserto piano in rovere spessart, olmo nero, cinque marmi levigati e sei lucidi o vetro lucido colori.

Structure and frame of the top in solid wood, spessart oak or black elm finish. Top insert in spessart oak, black elm, five mat and six glossy marble finishes or glossy glass in the available colours.

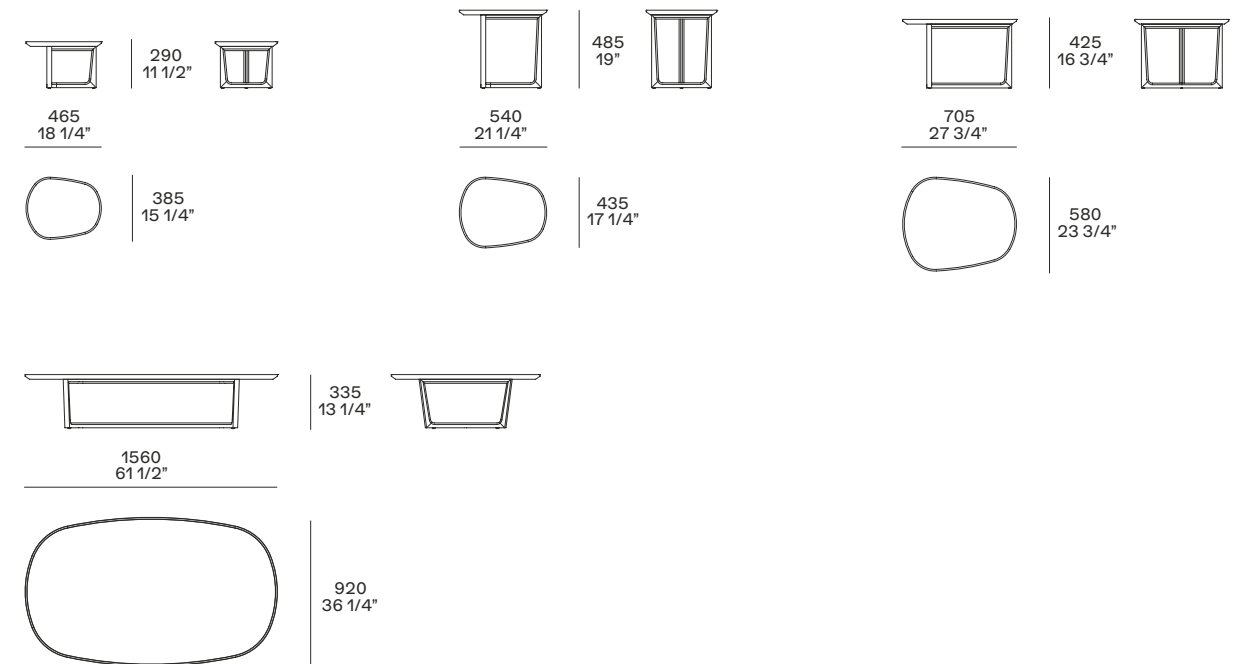



MAD COFFEE TABLE

Della nutrita collezione Mad, ideata da Marcel Wanders, fanno parte anche i tavolini realizzati in altezze differenti da accostare fra loro. Della collezione i tavolini mantengono le particolari gambe inclinate in essenza e le forme morbide che arrotondano i piani, in essenza o marmo.

Of the large collection Mad, designed by Marcel Wanders, these coffee tables are made in different heights to be used together. Of the collection, the tables maintain the particular, inclined, wooden legs and the soft shapes that round the tops, in wood or marble.



Nella pagina precedente: tavolino Mad Coffee Table in olmo nero e piano in marmo grigio stardust levigato. Poltrona Mad Queen rivestimento non sfoderabile, esterno in tessuto Norway 03 nero e interno in velluto Gibson matelassé 07 grafite, gambe in rovere cenere. In questa pagina: tavolini Mad Coffee Table in rovere cenere con piani in rovere cenere e in marmo calacatta oro levigato.

Previous page: Mad coffee table in black elm and top in mat marble grigio stardust. Mad Queen armchair with non-removable cover, outer cover in fabric Norway 03 nero and inner cover in velvet Gibson matelassé 07 grafite, legs in spessart oak. This page: Mad coffee tables in cenere oak with top in cenere oak and in mat marble calacatta oro.





In questa pagina: tavolino Mad Coffee Table in rovere cenere con piano in marmo noir saint laurent lucido. Nella pagina successiva: tavolino Mad Coffee Table in olmo nero con piano in marmo emperador dark levigato. Divano Dune rivestito in tessuto sfoderabile Caledonia 05 bianco. Tappeto Frame gold.

This page: Mad coffee table in cenere oak with top in glossy marble noir saint laurent. Next page: Mad coffee table in black elm with top in mat marble emperador dark. Dune sofa covered in removable fabric Caledonia 05 bianco. Carpet Frame gold.





MAD COFFEE TABLE

Design Marcel Wanders, 2015

Struttura in massello, finitura in rovere spessart, rovere cenere o olmo nero.
Piano in massello, finitura in rovere spessart, rovere cenere o olmo nero. Piano in marmo bianco carrara e calacatta oro levigati e lucidi o in noir saint laurent lucido.

Structure in solid wood finish spessart oak, cenere oak or black elm. Top in solid wood finish spessart oak, cenere oak or black elm. Top in mat and glossy marble bianco carrara and calacatta oro or in glossy marble noir saint laurent.

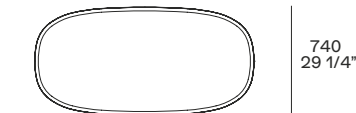
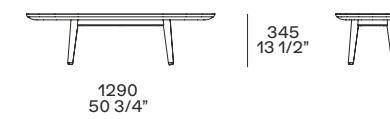

POUFS

I pouf sono complementi eleganti e versatili – poggiatesta, tavolini e sedute allo stesso tempo. Classici abbinati a poltrone e divani o come sedute aggiuntive nella zona giorno, sono immancabili nella zona notte e nella cabina armadio come elementi d'appoggio. I pouf Poliform sono disegnati da Jean-Marie Massaud ed Emmanuel Gallina.

The poufs are elegant and versatile complements – footrests, coffee tables, and seats at the same time. Classic when combined with armchairs and sofas or as additional seats in the day area, they are a must in the night area and in the walk-in closet as support elements. Poliform poufs are designed by Jean-Marie Massaud and Emmanuel Gallina.

POUFS

NEW YORK	189
HENRY	201
PLAY	211
ONDA	221
ELISE	231
GANT	241



NEW YORK

Poggiapiedi o elemento freestanding, il pouf New York è ideale accanto al divano, in camera da letto o dentro la cabina armadio. Disegnato da Jean-Marie Massaud, è valorizzato dai piedini forgiati in fonderia e caratterizzato dalle cuciture rifinite a mano, un dettaglio di alta sartoria.

Footrest or freestanding element, the New York pouf is ideal next to the sofa, in the bedroom, or inside the walk-in closet. Designed by Jean-Marie Massaud, it is enhanced by the feet forged in a foundry and characterized by hand-stitched seams, a high-tailoring detail.



Nella pagina precedente: pouf New York rivestimento sfoderabile in tessuto Skyros 02 sabbia e in pelle non sfoderabile Soft 10 prugna, piedini brown nickel lucido. Cabina armadio Ubik con pannelli in nobilitato Skin laccato opaco 94 latte, attrezzatura in nobilitato rovere cenere, tecnopelle 05 latte, vetro riflettente fumé 5059 e verniciato ardesia. In questa pagina: pouf New York rivestimento sfoderabile in tessuto Olimpia 11 polvere e in velluto Persia 1404 carbone, piedini in materiale plastico.

Previous page: New York pouf with removable cover in fabric Skyros 02 sabbia and in non-removable leather Soft 10 prugna, glossy brown nickel feet. Ubik walk-in closet with backs in 94 latte mat lacquered Skin melamine, equipment in cenere oak melamine, techno leather 05 latte, fumé reflecting glass 5059 and painted ardesia. This page: New York pouf with removable cover in fabric Olimpia 11 polvere and in velvet Persia 1404 carbone, feet in plastic material.







Nella pagina precedente: pouf New York rivestimento sfoderabile in tessuto Lipsi 15 prugna, velluto Persia 2006 prugna e in pelle non sfoderabile Nabuk 02 tortora, piedini brown nickel lucido. In questa pagina: pouf New York rivestimento sfoderabile in tessuto Naxos 27 prussia e piedini brown nickel lucido. Nella pagina successiva: pouf New York rivestimento sfoderabile in tessuto Norway 08 avorio e piedini brown nickel opaco.

Previous page: New York pouf with removable cover in fabric Lipsi 15 prugna, velvet Persia 2006 prugna and in non-removable leather Nabuk 02 tortora, glossy brown nickel feet. This page: New York pouf with removable cover in fabric Naxos 27 prussia and glossy brown nickel feet. Next page: New York pouf with removable cover in fabric Norway 08 avorio and mat brown nickel feet.

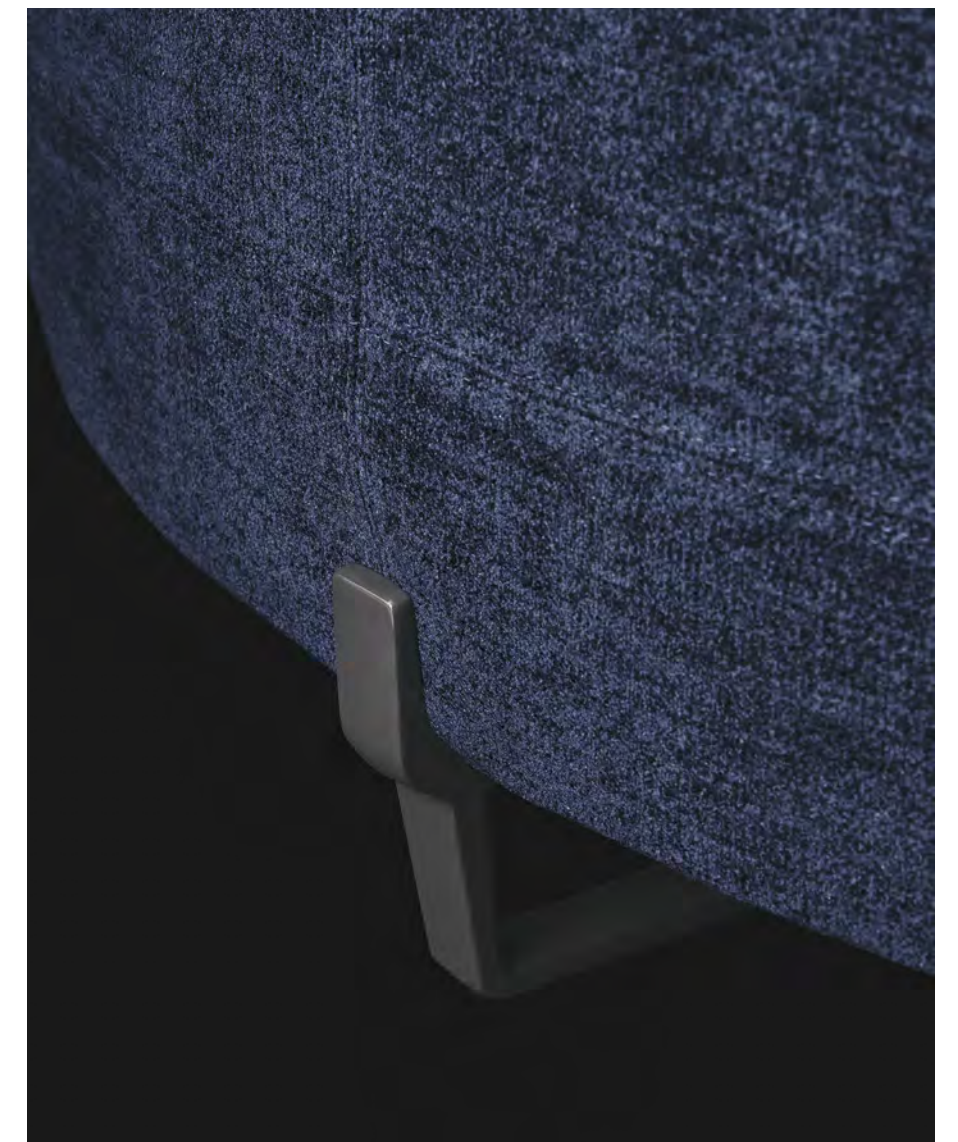



NEW YORK

Design Jean-Marie Massaud, 2017

Struttura in legno e derivati. Seduta in poliuretano espanso a quote differenziate e prerivestimento in ovatta di poliestere. Piedini in materiale plastico o in metallo verniciato brown nickel opaco o lucido. Rivestimento in tessuto sfoderabile o pelle non sfoderabile.

Structure in wood and wood by-products. Seat in multi-density polyurethane foam and pre-cover in polyester padding. Feet in plastic material or in painted metal mat or glossy brown nickel. Cover in removable fabric or non-removable leather.

Piedini in metallo Feet in metal

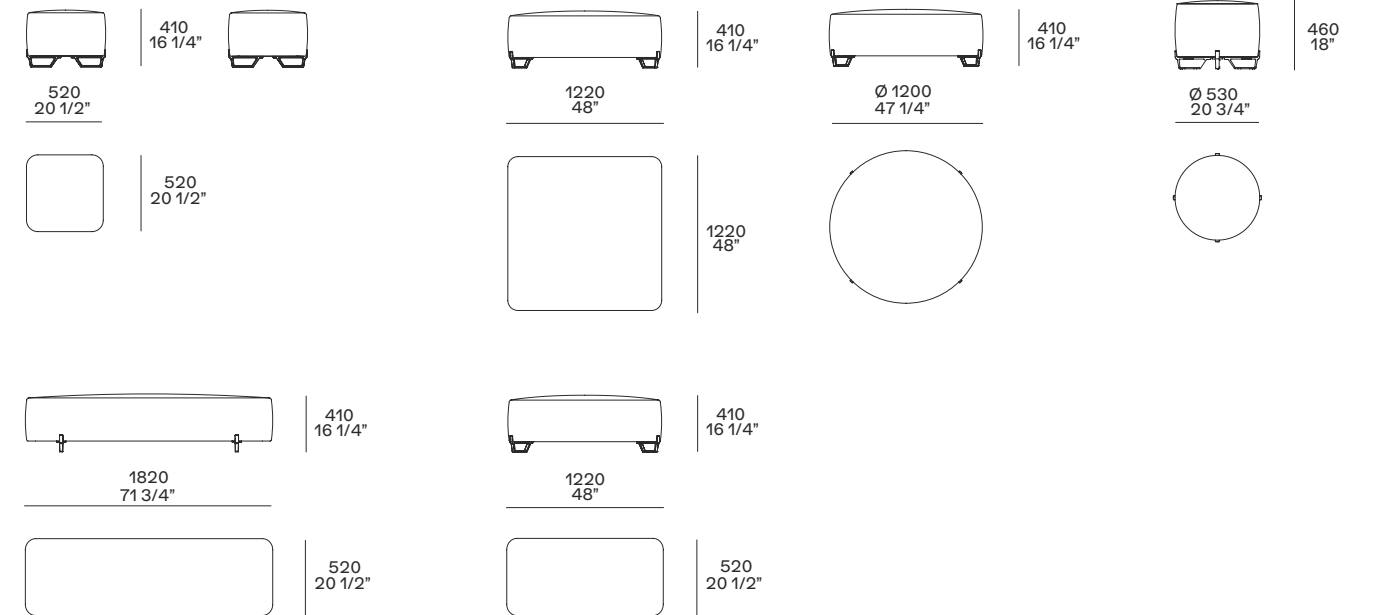

Piedini in materiale plastico Feet in plastic material

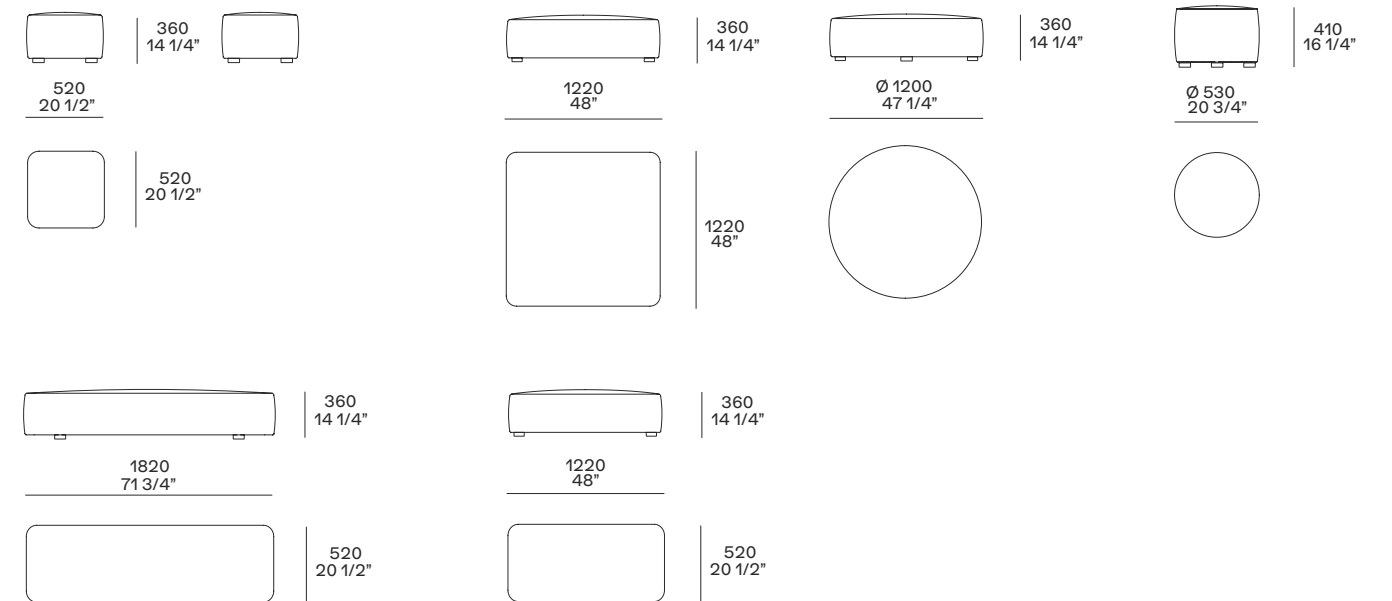



HENRY

Emmanuel Gallina disegna un complemento eclettico – pouf, sgabello e tavolino allo stesso tempo. Sulla base in essenza, l'imbottitura tonda o rettangolare è disponibile con rivestimento in tessuto o pelle.

Emmanuel Gallina designs an eclectic complement – pouf, stool, and coffee table at the same time. On the wooden base, the round or rectangular padding is available in fabric or leather.



Nella pagina precedente: pouf Henry rivestimento non sfoderabile in velluto Persia 1404 carbone e struttura in olmo nero. Sistema giorno Quid con boiserie in olmo nero e profili in brown nickel opaco, mensole in laccato opaco moka e cuoio 29 tortora. Contenitori sospesi in vetro riflettente blu con piano in marmo lucido noir saint laurent e fianchi laterali in olmo nero. Tappeto Frame carbone. In questa pagina: pouf Henry rivestimento non sfoderabile in pelle Nabuk 09 ruggine e struttura in olmo nero.

Previous page: Henry pouf with non-removable cover in velvet Persia 1404 carbone and black elm structure. Day system Quid with wall panelling in black elm and mat brown nickel profiles, shelves in moka mat lacquer and hide 29 tortora. Hanging storage units in blu reflecting glass with top in glossy marble noir saint laurent, lateral side panels in black elm. Carpet Frame carbone. This page: Henry pouf with non-removable cover in leather Nabuk 09 ruggine and black elm structure.





In questa pagina: pouf Henry rivestimento non sfoderabile in tessuto Kitami 02 cenere e struttura in olmo nero. Nella pagina successiva: pouf Henry rivestimento non sfoderabile in velluto Persia 1404 carbone e struttura in olmo nero. Divano Bristol rivestito in tessuto sfoderabile Naxos 17 corda con cuscini Zante 10 nero. Poltrona Jane rivestimento sfoderabile in tessuto Persia 54 prussia e basamento in olmo nero. Tavolino Baba in metallo verniciato oro lucido e piano in vetro oro. Tavolino Home Hotel in olmo nero. Tappeto Frame carbone.

This page: Henry pouf with non-removable cover in fabric Kitami 02 cenere and black elm structure. Next page: Henry pouf with non-removable cover in velvet Persia 1404 carbone and structure in black elm. Bristol sofa covered in removable fabric Naxos 17 corda with cushions in Zante 10 nero. Jane armchair with removable cover in fabric Persia 54 prussia and base in black elm. Baba coffee table in glossy gold painted metal and top in gold glass. Home Hotel coffee table in black elm. Carpet Frame carbone.





HENRY

Design Emmanuel Gallina, 2017

Seduta in poliuretano espanso a quote differenziate. Prerivestimento parti in tela cotone con piuma e parti in ovatta di poliestere accoppiata. Rivestimento non sfoderabile in tessuto o pelle. Struttura in massello, finitura rovere spessart o olmo nero.

Seat in multi-density polyurethane foam. Pre-cover with parts in cotton cloth with feather and parts in polyester padding. Non-removable cover in fabric and leather. Solid wood structure finish spessart oak or black elm.

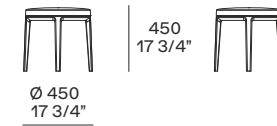

Ø 450
17 3/4"



615
24 1/2"



400
15 3/4"



PLAY

Il pouf Play unisce a linee semplici il comfort dell'imbottitura e del rivestimento in tessuto o pelle, anche con lavorazioni particolari come il fondo piega, la cucitura matelassé e la pelle Nabuk intrecciata.

The Play pouf combines simple lines with the comfort of the padding and upholstery in fabric or leather, also with particular details such as the slipcover, the matelassé stitching, and the woven Nabuk leather.



Nella pagina introduttiva: pouf Play rivestimento sfoderabile in tessuto Zante 17 melanzana e in pelle non sfoderabile Nabuk intrecciata 01 latte. Nella pagina precedente: pouf Play rivestimento sfoderabile in velluto Gibson matelassé 07 grafite. Sistema giorno Quid boiserie in olmo nero e bacheche con struttura in laccato opaco piombo con cassetti in olmo nero. In questa pagina: pouf Play rivestimento non sfoderabile in pelle Nabuk 01 latte e su 3 facciate centrali in pelle Nabuk intrecciata 01 latte.

Introduction page: Play pouf with removable cover in fabric Zante 17 melanzana and in non-removable woven leather Nabuk 01 latte. Previous page: Play pouf with removable cover in velvet Gibson matelassé 07 grafite. Day system Quid with wall panelling in black elm, open display cases with piombo mat lacquered structure and black elm drawers. This page: Play pouf with non-removable cover in leather Nabuk 01 latte and on the three central sides in woven leather Nabuk 01 latte.





In questa pagina: pouf Play rivestimento sfoderabile versione fondo-piega in tessuto Skyros 05 ghiaccio. Nella pagina successiva: pouf Play rivestimento sfoderabile in velluto Persia 58 danubio. Cabina armadio Ubik con pannelli a parete laccato opaco visone e attrezzature in nobilitato rovere cenere e verniciato ardesia.

This page: Play pouf with removable cover with slipcover in fabric Skyros 05 ghiaccio. Next page: Play pouf with removable cover in velvet Persia 58 danubio. Ubik walk-in closet with wall mounted back panels in mat lacquer visone and equipment in cenere oak melamine and painted ardesia.





PLAY

Design R&D Poliform, 2003

Struttura in legno e derivati. Seduta in poliuretano espanso a quote differenziate e prerivestimento in fibra di poliestere accoppiata. Piedini in materiale plastico. Rivestimento versione tesato sfoderabile in tessuto o non sfoderabile in pelle. Rivestimento Gibson matelassé e pelle intrecciata Nabuk su tre facciate centrali del pouf solo per la versione rivestimento tesato. Rivestimento versione fondopiega sfoderabile in tessuto.

Structure in wood and wood-by products. Seat in multi-density polyurethane foam and pre-cover in polyester fibre. Feet in plastic material. Version with stretched cover removable in fabric and non-removable in leather. Cover Gibson matelassé and Nabuk woven leather on the three central sides of the pouf only for the version with stretched cover. Version with slipcover removable in fabric.

Rivestimento tesato Stretched cover



Rivestimento fondopiega Slipcover

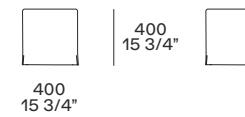

ONDA

Un cubo perfetto con un'impuntura centrale che ne sottolinea comodità e morbidezza. Il pouf Onda, disegnato da Poliform, completa il divano della zona giorno, diventando una comoda seduta aggiuntiva quando serve.

A perfect cube with central stitching that emphasizes its comfort and softness. The Onda pouf, designed by Poliform, completes the sofa in the day area, becoming a comfortable additional seat when needed.



Nella pagina precedente: pouf Onda rivestimento sfoderabile in tessuto Skyros 07 grafite. Consolle Mondrian piano in marmo lucido noir saint laurent e struttura in fusione di bronzo lucidata oro. Divano Mondrian in tessuto sfoderabile Olimpia 11 polvere. Sistema a giorno Quid con boiserie in olmo nero. In questa pagina: pouf Onda rivestimento non sfoderabile in pelle Nabuk 01 latte.

Previous page: Onda pouf with removable cover in fabric Skyros 07 grafite. Mondrian console with top in glossy marble noir saint Laurent and structure in gold polished bronze casting. Mondrian sofa in removable fabric Olimpia 11 polvere. Day system Quid with black elm wall panelling. This page: Onda pouf with non-removable cover in leather Nabuk 01 latte.





In questa pagina: pouf Onda rivestimento sfoderabile in tessuto Olimpia 113 porpora. Nella pagina successiva: pouf Onda rivestimento non sfoderabile in pelle Soft 04 cognac. Tavolino Bristol con piano in marmo calacatta oro levigato.

This page: Onda pouf with removable cover in fabric Olimpia 113 porpora. Next page: Onda pouf with non-removable cover in leather Soft 04 cognac. Bristol coffee table with top in mat marble calacatta oro.

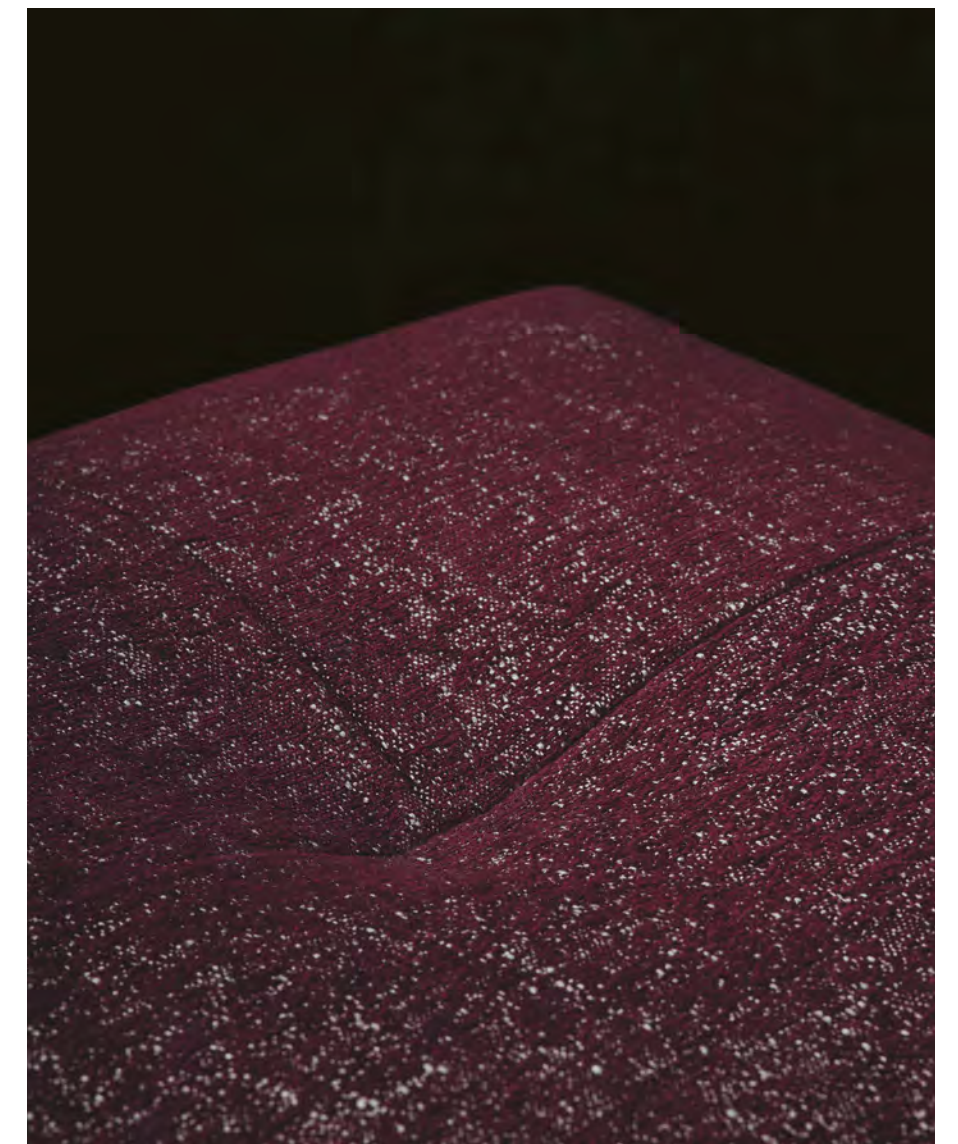



ONDA

Design R&D Poliform, 2003

Struttura in legno e derivati. Seduta in poliuretano espanso a quote differenziate e prerivestimento in fibra di poliestere. Piedini in materiale plastico. Rivestimento in tessuto sfoderabile o pelle non sfoderabile, lavorazione capitonné.

Structure in wood and wood by-products. Seat in multi-density polyurethane foam and pre-cover in polyester fibre. Feet in plastic material. Cover in removable fabric or non-removable leather, capitonné manufacturing.

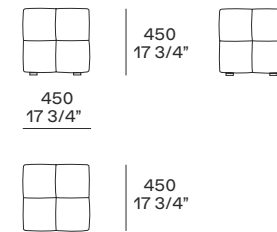

ELISE

Elise è un pouf di forma circolare dalle dimensioni generose. Un'estetica della morbidezza firmata Poliform ed enfatizzata da un'ampia gamma di rivestimenti, anche con bordura a contrasto.

Elise is a round shaped pouf with generous dimensions. An aesthetic of softness by Poliform emphasized by a wide range of coverings, also with contrast edge.



Nella pagina precedente: pouf Elise rivestimento sfoderabile in tessuto Atlanta 09 juta e cucitura a cordoncino nero. Tavolino Ipsilon in rovere spessart. In questa pagina: pouf Elise rivestimento non sfoderabile in pelle Special 30 cemento e cucitura normale doppia.

Previous page: Elise pouf with removable cover in fabric Atlanta 09 juta and drawstring stitching nero. Ipsilon coffee table in spessart oak. This page: Elise pouf with non-removable cover in leather Special 30 cemento and normal double stitching.





In questa pagina: pouf Elise rivestimento sfoderabile in tessuto Zante 18 rubino e cucitura normale doppia. Nella pagina successiva: pouf Elise rivestimento non sfoderabile in pelle Nabuk 01 latte. Poltrona Mad Queen rivestimento non sfoderabile, esterno e gambe in pelle Nabuk 01 latte, interno in tessuto Norway 08 avorio. Letto Bruce con testata sfoderabile Zante 10 nero e giroletto in velluto sfoderabile Persia 23 arena.

This page: Elise pouf with removable cover in fabric Zante 18 rubino and normal double stitching. Next page: Elise pouf with non-removable cover in leather Nabuk 01 latte. Mad Queen armchair with non-removable cover, outer cover and legs in leather Nabuk 01 latte, inner cover in fabric Norway 08 avorio. Bruce bed, headboard in removable fabric Zante 10 nero and bedframe in removable velvet Persia 23 arena.

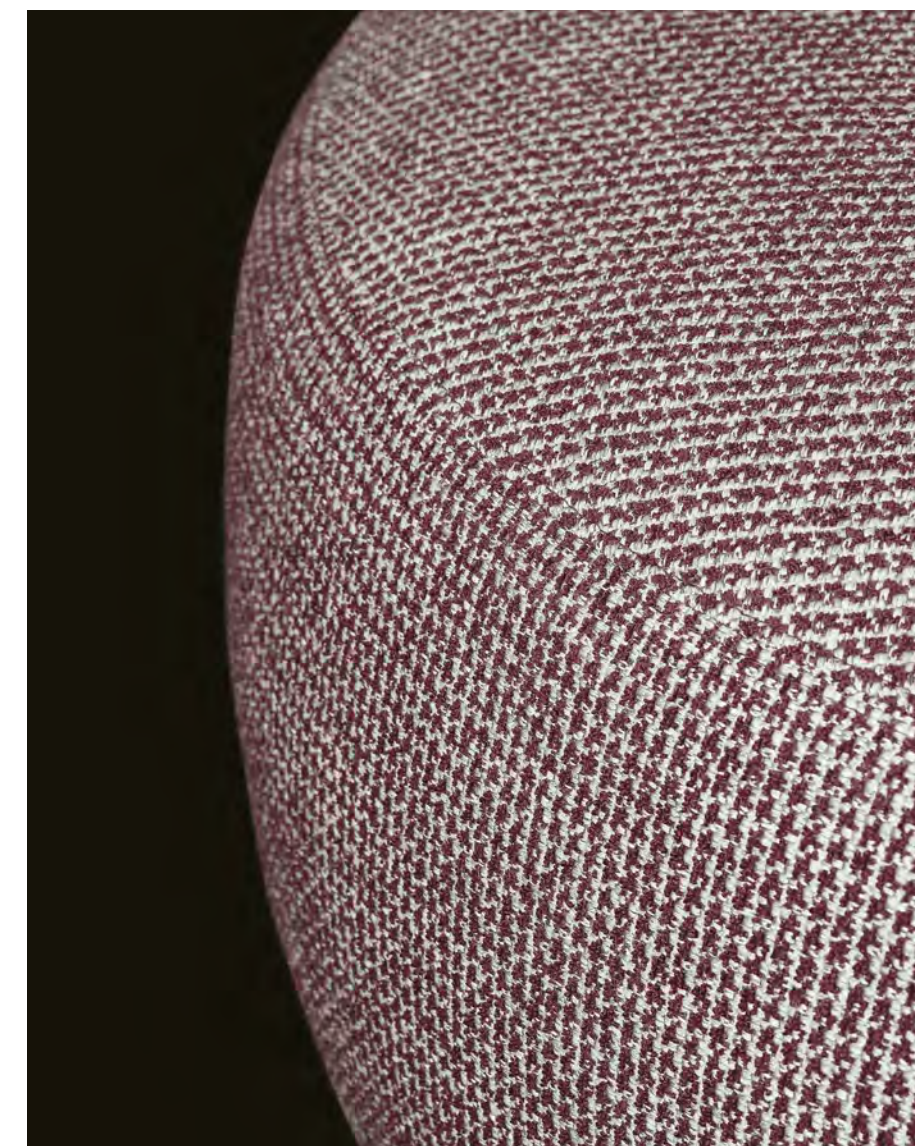



ELISE

Design R&D Poliform, 2011

Struttura in legno e derivati. Seduta in poliuretano espanso a quote differenziate e prerivestimento in tela cotone e piuma. Piedini in materiale plastico. Rivestimento in tessuto sfoderabile o pelle non sfoderabile. Cucitura normale doppia o a cordoncino con filato nei diversi colori da campionario (escluso rivestimento in pelle e velluto).

Structure in wood and wood-by products. Seat in multi-density polyurethane foam and pre-cover in cotton cloth and feather. Feet in plastic material. Cover in removable fabric or non-removable leather. Normal double stitching or drawstring stitching with yarn in the colours as per sample book (except for cover in leather and in velvet).

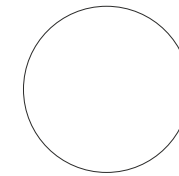
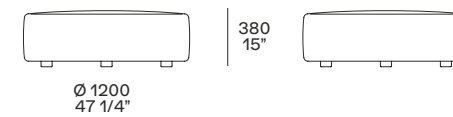



GANT

Poliform reinterpreta in chiave attuale il classico pouf quadrato. Rivestito in tessuto o pelle con preziosa lavorazione capitonné, Gant si fa notare per la sua eleganza.

Poliform reinterprets the classic square pouf in a modern key. Covered in fabric or leather with precious capitonné style, Gant stands out for its elegance.



Nella pagina precedente: pouf Gant rivestimento non sfoderabile in pelle Invecchiata 880 nero. Tavolino Flute in laccato opaco carbone. In questa pagina: pouf Gant rivestimento non sfoderabile in pelle Soft 04 cognac. Sotto: dettaglio della lavorazione capitonné.

Previous page: Gant pouf with non-removable cover in leather Invecchiata 880 nero. Carbone mat lacquered Flute coffee table. This page: Gant pouf with non-removable cover in leather Soft 04 cognac. Below: close up of the capitonné manufacturing.





In questa pagina: pouf Gant rivestimento non sfoderabile in tessuto Naxos 27 prussia. Nella pagina successiva: pouf Gant rivestimento non sfoderabile in pelle Nabuk 01 latte. Tavolino Tribeca verniciato brown nickel opaco e piano in marmo emperador dark lucido. Cabina armadio Senzafine in nobilitato rovere cenere.

This page: Gant pouf with non-removable cover in fabric Naxos 27 prussia. Next page: Gant pouf with non-removable cover in leather Nabuk 01 latte. Tribeca coffee table mat brown nickel and top in glossy marble emperador dark. Walk-in closet Senzafine in nobilitato rovere cenere.





GANT

Design R&D Poliform, 2010

Struttura in legno e derivati. Seduta in poliuretano espanso a quote differenziate e prriverestimento in fibra di poliestere. Piedini in materiale plastico. Rivestimento non sfoderabile in tessuto o pelle, lavorazione capitonné.

Structure in wood and wood-by products. Seat in multi-density polyurethane foam and pre-cover in polyester fibre. Feet in plastic material. Non-removable cover in fabric and leather, capitonné manufacturing.

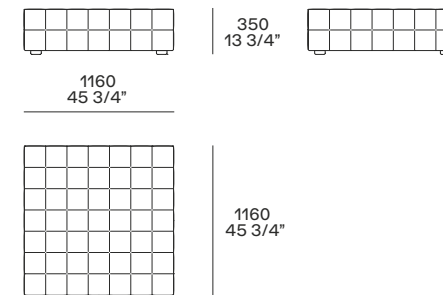

CARPETS

Per completare i suoi arredi, Poliform propone una collezione di tappeti realizzati con tecnica handloom, una lavorazione eseguita a mano su telaio che si differenzia dai metodi di fabbricazione automatizzati e meccanici. Tappeti unici, realizzati con materiali naturali come la lana himalayana e l'aloè, morbidi e duraturi nel tempo, dagli accostamenti cromatici eleganti.

To complete its furnishings, Poliform offers a collection of carpets made with handloom technique, a hand-made manufacturing process on a loom that differs from automated and mechanical manufacturing methods. Unique carpets, made with natural materials such as Himalayan wool and aloe, soft and long-lasting, with elegant colour combinations.

CARPETS

FRAME	255
PLAIN	261
SOFT	267
DAMA	273
STRIPES	279

FRAME

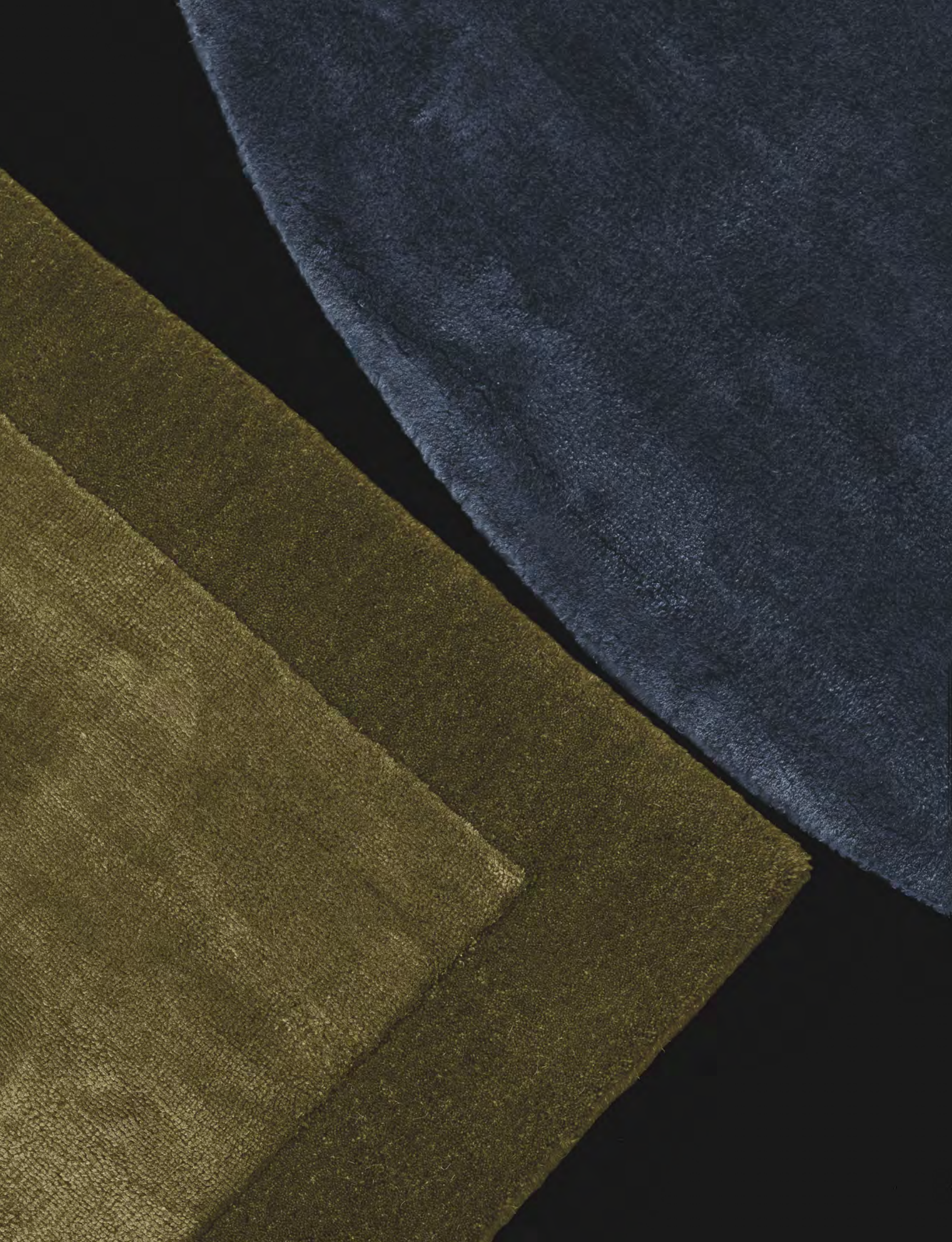

Frame è realizzato in seta di bambù, un materiale che conferisce al tappeto il suo caratteristico aspetto cangiante. Disponibile in versione ovale o rettangolare, in questa variante è caratterizzato dal bordo monocromatico in lana himalayana della stessa tinta.

Frame is made of bamboo silk, a material that gives the carpet its characteristic iridescence. Available in oval or rectangular version, the latter is characterized by the monochromatic edge in Himalayan wool of the same colour.





FRAME

Design R&D Poliform, 2015

Prodotto a mano con tecnica handloom.
Trama in cotone, vello in seta di bambù.
Bordo perimetrale di 80 mm in lana himalayana in tinta solo per la versione rettangolare.
Dimensioni mm: rettangolare 1700×2400
2300×3000 - 3000×4000
quadrato 3000×3000 - ovale 2300×4000.

Handmade with the handloom technique.
Cotton weave, fleece in bamboo silk.
80 mm - 3 1/4" perimeter edge in Himalayan wool in matching color only for the rectangular version.
Dimensions inches: rectangular 67"x94 1/2"
90 1/2"x118" - 118"x157 1/2"
square 118"x118" - oval 90 1/2"x157 1/2".



Grey

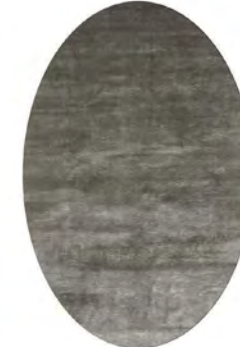

Gold



Perla



Oceano

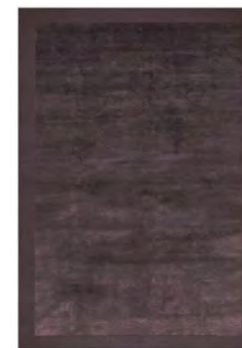

Prugna



Carbone



Nella pagina precedente: tappeto Frame carbone. In questa pagina: tappeto ovale Frame perla.

Previous page: carpet Frame carbone. This page: oval carpet Frame perla.



PLAIN

Rettangolare o tondo, il tappeto Plain è realizzato in un blend di aloe e seta di bambù, due materiali molto resistenti e di qualità eccellente. Disponibile in cinque colori, è caratterizzato in entrambe le versioni dalle sezioni più scure, in tinta.

Rectangular or round, the Plain carpet is made of a blend of aloe and bamboo silk, two very resistant materials of excellent quality. Available in five colours, it is characterized in both versions by the darker sections of the same hue.





PLAIN

Design R&D Poliform, 2015

Prodotto a mano con tecnica handloom.
Trama in cotone, vello in aloe e seta di bambù. Versione rettangolare bordo di 150 mm in tonalità più scura sul lato superiore e inferiore e di 100 mm per la dimensione 1700x2400. Nella versione tonda la parte più scura è di 1/4 del tappeto.
Dimensioni mm: rettangolare 1700x2400
2300x3000 - 3000x4000
quadrato 3000x3000 - rotondo Ø 2500.

Handmade with the handloom technique.
Cotton weave, fleece in aloe and bamboo silk.
Rectangular version 150 mm - 6" edge in darker colour in the upper and lower side and 100 mm - 4" edge for the size 1700x2400.
In the round version the darkest part is 1/4 of the carpet.
Dimensions inches: rectangular 67"x94 1/2"
90 1/2"x118" - 118"x157 1/2"
square 118"x118" - round Ø 94 1/2".



Tortora

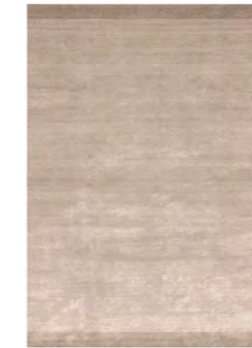
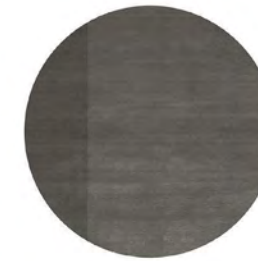

Cipria



Ruggine



Arena



Natural



Nella pagina precedente: tappeto Plain tortora. In questa pagina: tappeto Plain natural.

Previous page: carpet Plain tortora. This page: carpet Plain natural.



SOFT

Dall'intreccio di venticinque diverse tonalità di grigio nasce il tappeto Soft, che si riconosce per le sfumature e l'aspetto cangiante dato dalla seta di bambù. Di forma rettangolare, Soft è un tappeto morbido e raffinato.

From the interweaving of twenty-five different shades of grey comes the Soft carpet, which distinguishes itself for the nuances and the iridescence given by the bamboo silk. Rectangular in shape, Soft is a soft and refined carpet.





SOFT

Design R&D Poliform, 2015

Prodotto a mano con tecnica handloom.
Trama in cotone, vello in seta di bambù
grigio sfumato.
Dimensioni mm: rettangolare 1700×2400
2300×3000 - 3000×4000
quadrato 3000×3000.

Handmade with the handloom technique.
Cotton weave, fleece in bamboo silk shaded
grey.
Dimensions inches: rectangular 67"x94 1/2"
90 1/2"x118" - 118"x157 1/2"
square 118"x118".





DAMA

Dama si riconosce per il motivo a scacchi, un pattern capace di dare un tocco vivace ma elegante a qualsiasi ambiente. La trama è in cotone, mentre nel vello s'intrecciano lana himalayana in tonalità natural e seta di bambù nera.

Dama distinguishes itself for its chequered pattern, capable of giving a lively yet elegant touch to any environment. The weave is made of cotton, while the fur is a blend of Himalayan wool in natural hues and black bamboo silk.





DAMA

Design R&D Poliform, 2015

Prodotto a mano con tecnica handloom.
Trama in cotone, vello in lana himalayana e
seta di bambù.

Dimensioni mm: rettangolare 1100×3500
1700×2400 - 2300×3000 - 3000×4000
quadrato 3000×3000.

Handmade with the handloom technique.
Cotton weave, fleece in Hymalayan wool and
bamboo silk.

Dimensions inches: rectangular 43 1/4"x137
1/4" - 67"x94 1/2" - 90 1/2"x118" - 118"x157
1/2" square 118"x118".



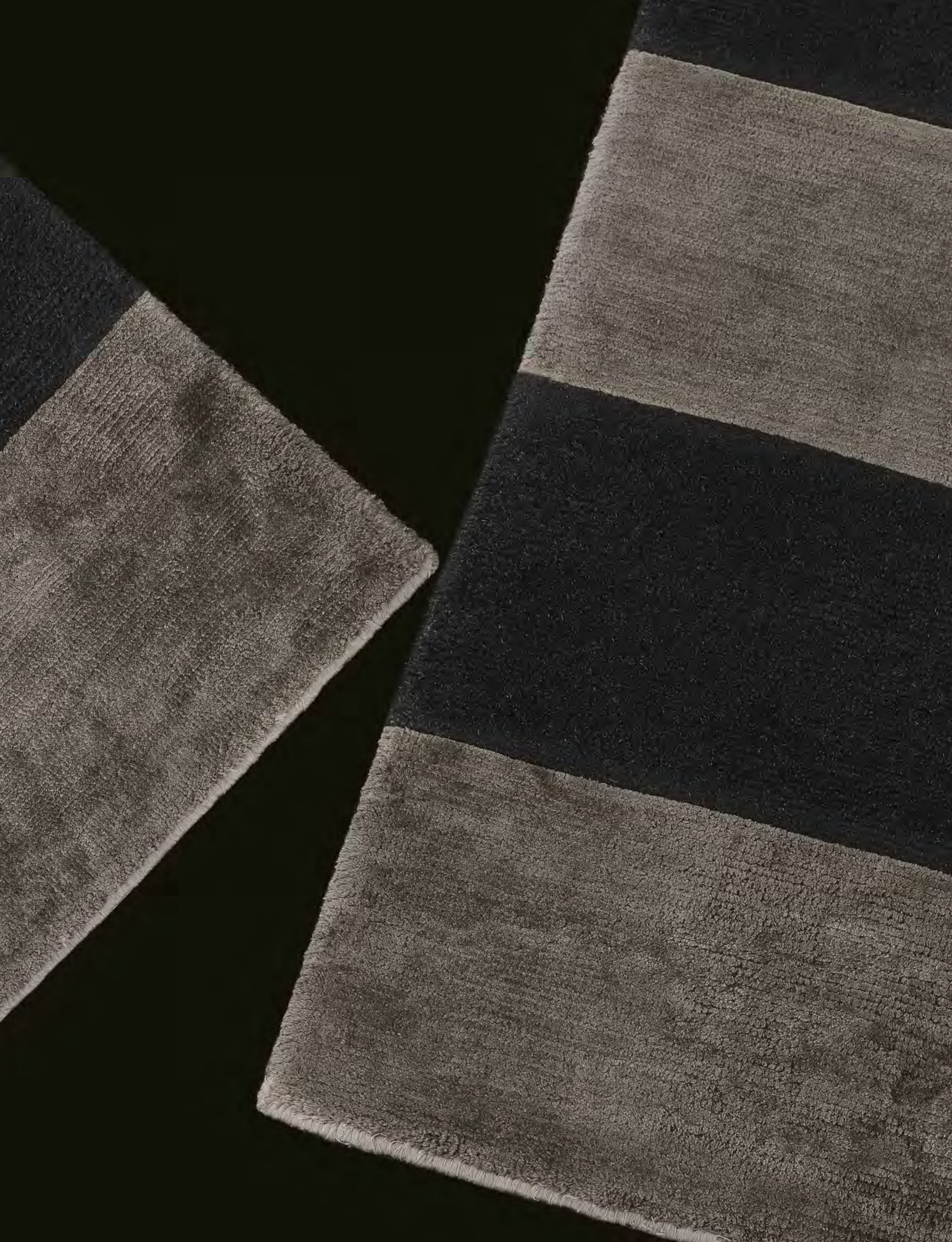

STRIPES

Stripes è un tappeto a righe, un classico della nostra collezione. Le righe nere sono in seta di bambù, mentre quelle in tonalità natural sono in lana himalayana.

Stripes is a striped carpet, a classic of our collection. The black lines are made of bamboo silk, while the ones in natural shades are made of Himalayan wool.

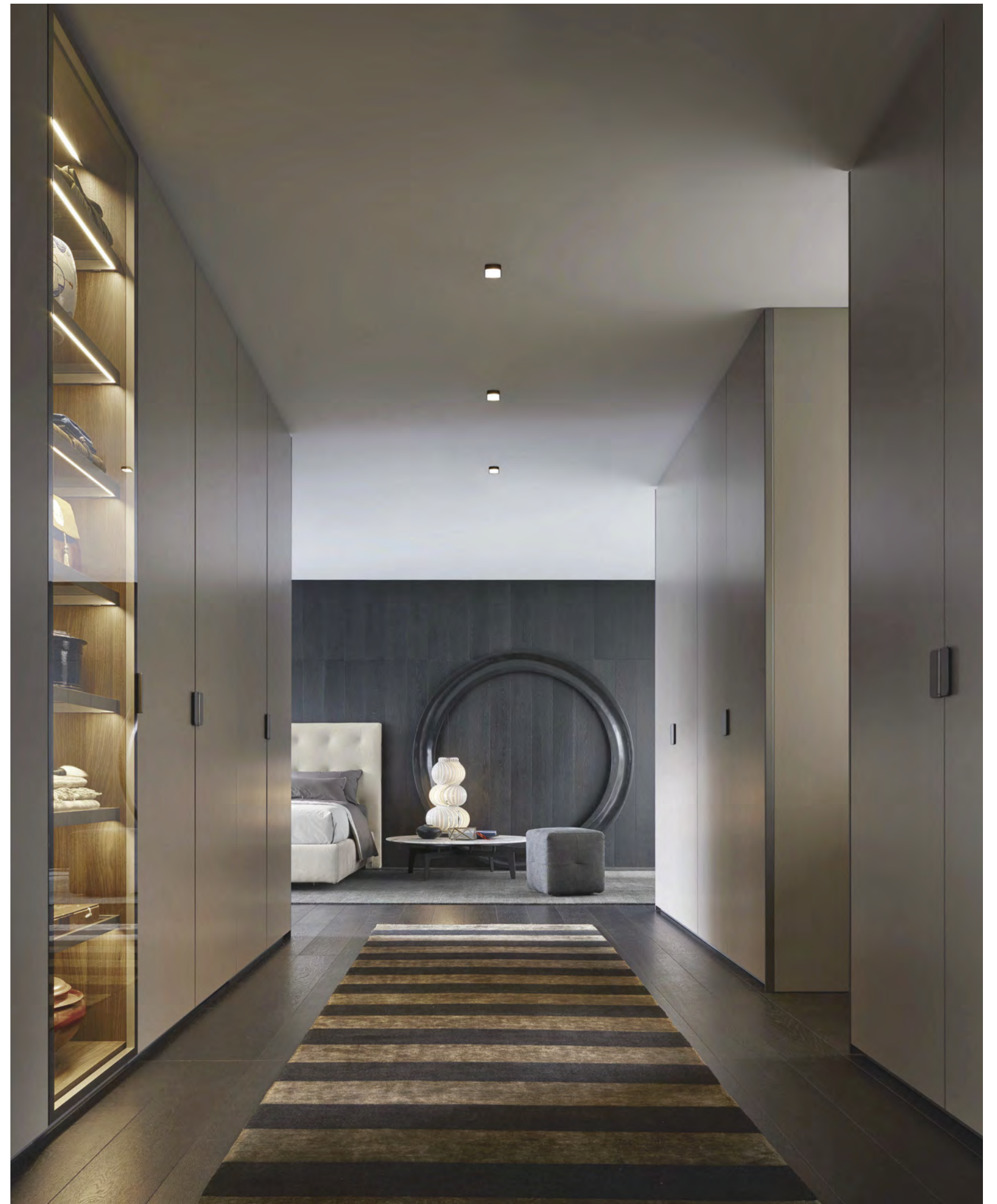



STRIPES

Design R&D Poliform, 2015

Prodotto a mano con tecnica handloom.
Trama in cotone, vello in lana himalayana e
seta di bambù.
Dimensioni mm: rettangolare 1100×3500
1700×2400 - 2300×3000 - 3000×4000
quadrato 3000×3000.

Handmade with the handloom technique.
Cotton weave, fleece in Hymalayan wool and
bamboo silk.
Dimensions inches: rectangular 43 1/4"x137
1/4" - 67"x94 1/2" - 90 1/2"x118" - 118"x157
1/2" square 118"x118".



TECHNICAL DATA

FINITURE
FINISHINGS

286

INDICE PRODOTTI
PRODUCT INDEX

292

FINITURE
FINISHINGS

Laccato opaco e lucido
Mat and glossy lacquered

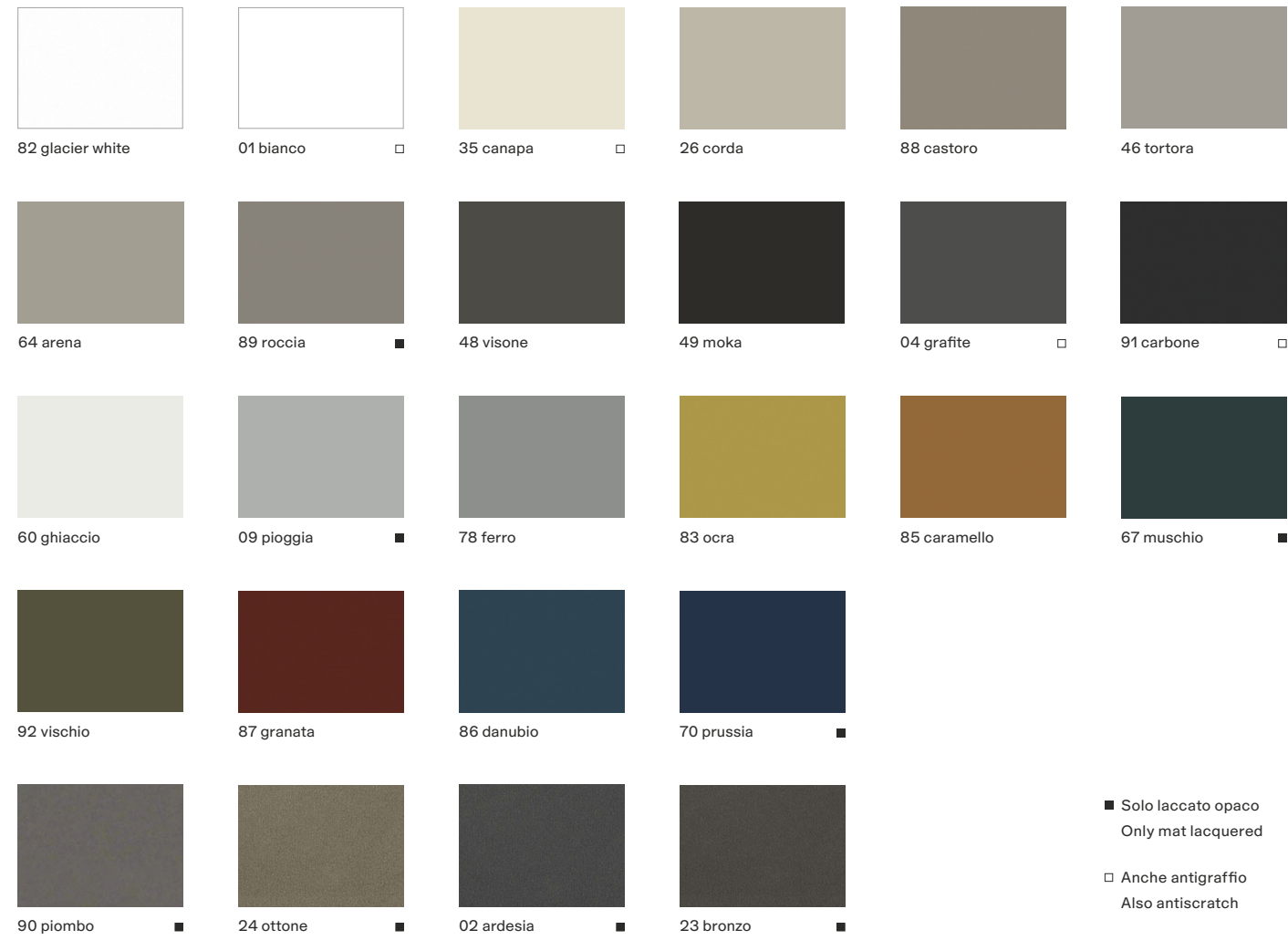

■ Solo laccato opaco
Only mat lacquered

□ Anche antigraffio
Also antiscratch

Laccato metallico
Metallic lacquered



Tecnopelle
Techno leather



Essenza
Wood

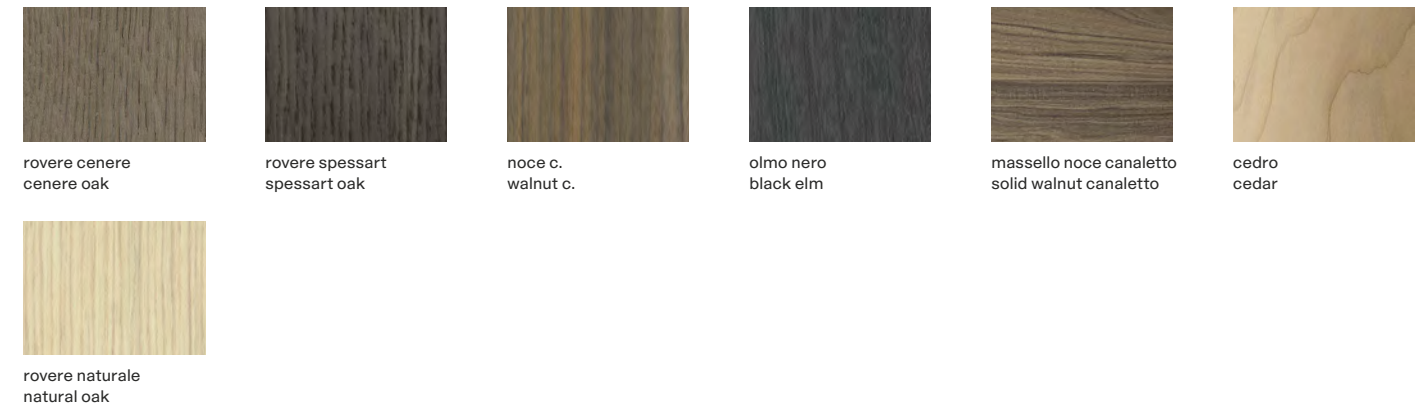

Nobilitato
Melamine

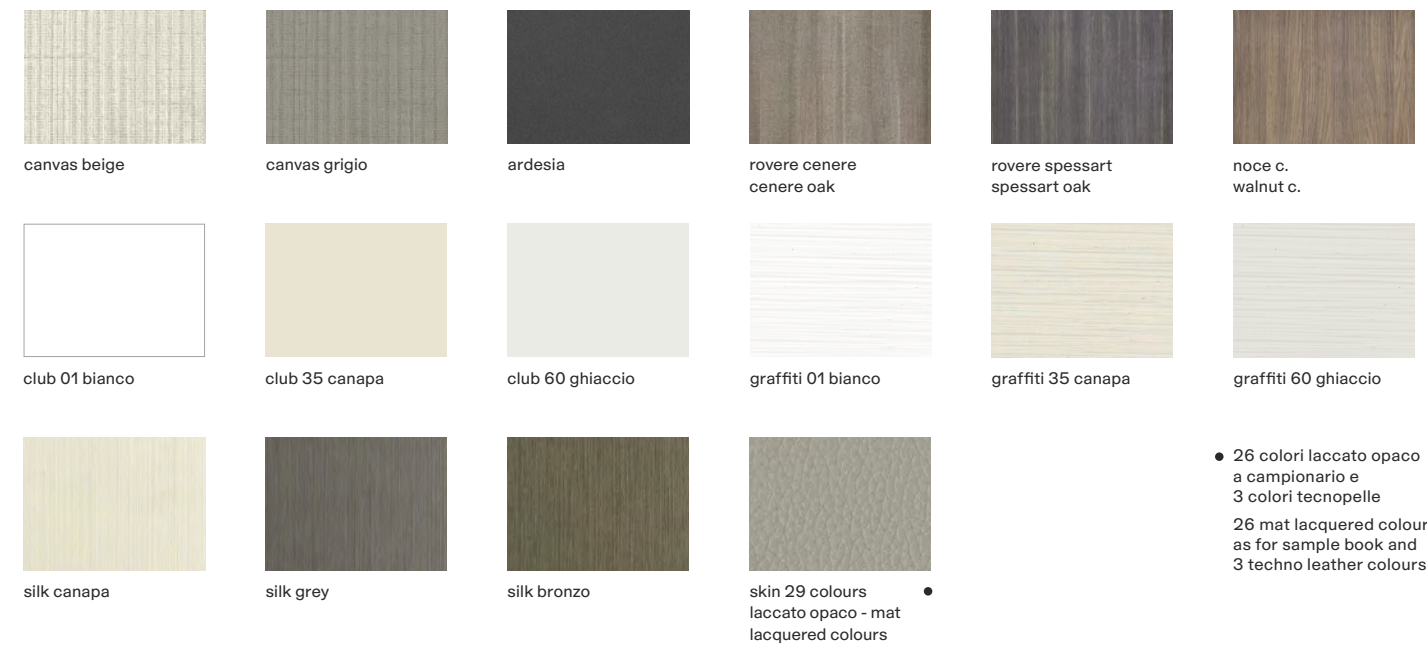

● 26 colori laccato opaco
a campionario e
3 colori tecnopelle
26 mat lacquered colours
as for sample book and
3 techno leather colours

Metacrilato
Methacrylate

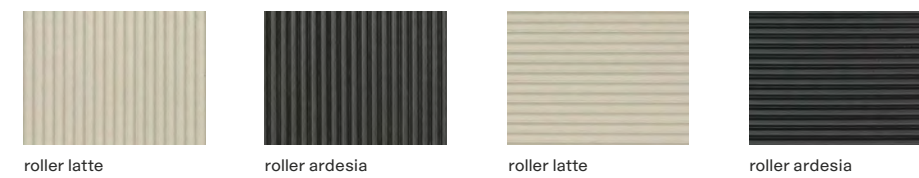

Nobilitato interno cassetti
Melamine drawers structure



FINITURE
FINISHINGS

**Vetro
Glass**



1000 trasparente
transparent



2000 trasparente
extrachiaro-transparent
extralight



3050 fumé

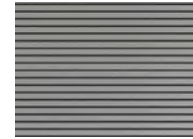

2700 line

**Vetro riflettente
Reflecting glass**

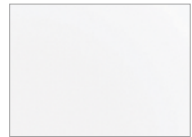

5000 trasparente
transparent

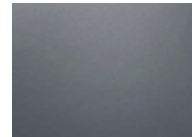

5010 blu



5051 bronzato
bronzed



5059 fumé

**Vetro acidato
Etched glass**



5380 acciaio

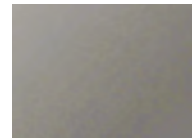

5323 bronzo

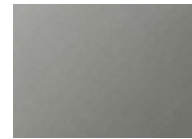

5325 titanio

**Specchio
Mirror**

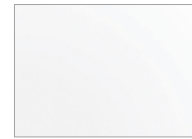

4000 bianco
white



4051 bronzato
bronzed

**Vetro satinato
Mat glass**

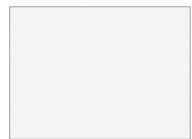

2301 bianco

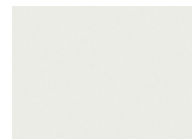

2373 ghiaccio

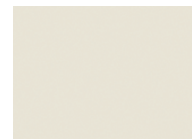

1335 canapa



1364 arena



1304 grafite



1303 nero

**Vetro lucido
Glossy glass**

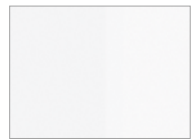

2201 bianco



2273 ghiaccio



1235 canapa



1264 arena



1204 grafite



1203 nero



1259 bordeaux

**Marmo levigato
Mat marble**



bianco carrara



calacatta oro

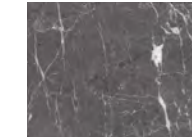

grigio stardust

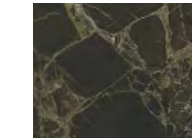

emperador dark

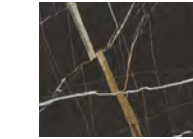

sahara noir
finitura poliestere
polyester finish

**Marmo lucido
Glossy marble**



bianco carrara



calacatta oro

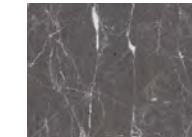

grigio stardust

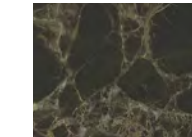

emperador dark

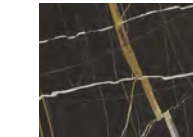

sahara noir
finitura poliestere
polyester finish



noir saint laurent

**Marmo e onice
Marble and onyx**

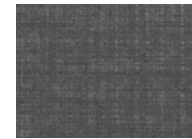

nero assoluto
texture juta



lapislazzulo blu
blue lapis lazuli

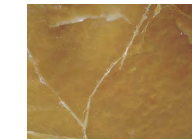

onice ambra
onyx amber

**Parti metalliche
Metal parts**

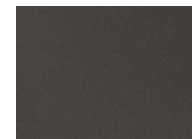

brown nickel opaco
mat brown nickel

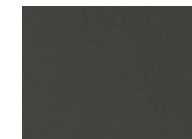

brown nickel lucido
glossy brown nickel

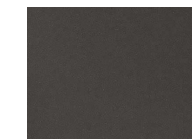

brown nickel satinato
brushed brown nickel



champagne opaco
mat champagne



champagne satinato
brushed champagne



cromo nero
black chrome



piombo
opaco - mat



ardesia
opaco - mat



bronzato
bronzed

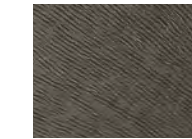

bronzo anticato
antique bronze



oro lucido
glossy gold



alluminio brill
aluminium brill

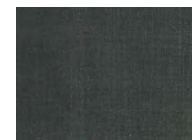

spatolato ferro
spatula-finish ferro

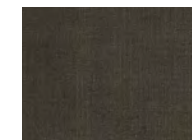

spatolato bronzo
spatula-finish bronzo

FINITURE
FINISHINGS

Tessuti
Fabrics

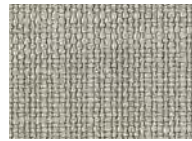

atlanta cat. b
12 colori - colours



chios cat. b
13 colori - colours

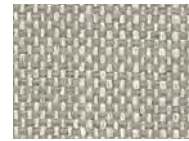

aspen cat. c
12 colori - colours

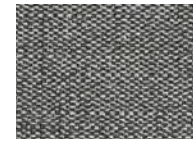

lima cat. c
11 colori - colours



saviglia cat. c
14 colori - colours



caledonia cat. d
9 colori - colours



cordoba cat. d
13 colori - colours



corinto cat. d
5 colori - colours



indra cat. d
12 colori - colours



itaca cat. d
10 colori - colours



kushiro cat. d
13 colori - colours



lipsi cat. d
11 colori - colours



milos cat. d
5 colori - colours



olimpia cat. d
14 colori - colours

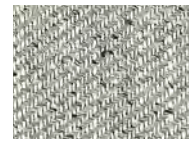

oxford cat. d
8 colori - colours



rabat cat. d
10 colori - colours



sendai cat. d
5 colori - colours



sparta cat. d
12 colori - colours



argo cat. e
13 colori - colours

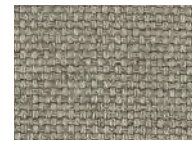

hannover cat. e
11 colori - colours

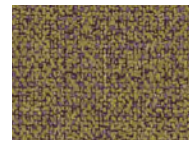

kitami cat. e
12 colori - colours



merida cat. e
8 colori - colours

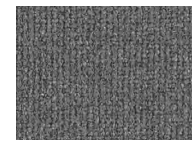

naxos cat. e
11 colori - colours



nayoro cat. e
10 colori - colours



norway cat. e
13 colori - colours

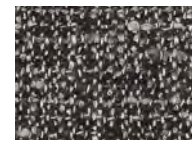

orleans cat. e
10 colori - colours



paros cat. e
11 colori - colours



persia cat. e
16 colori - colours

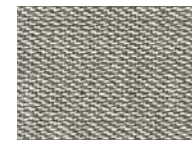

salford cat. e
11 colori - colours



skyros cat. e
12 colori - colours



zante cat. e
11 colori - colours

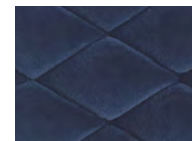

gibson cat. z
8 colori - colours

Cuoio
Hide



28 avorio

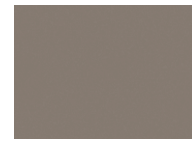

29 tortora



19 caffè



38 oliva

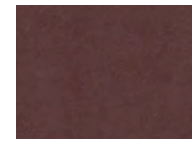

15 prugna



26 invecchiato



03 grigio scuro



02 nero

Pelle
Leather



spring cat. p
13 colori - colours

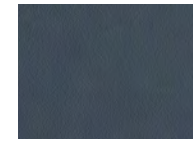

colors cat. s
25 colori - colours



vintage cat. s
5 colori - colours



special cat. x
21 colori - colours

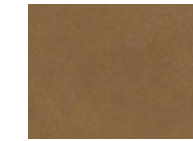

nabuk cat. y
10 colori - colours



nabuk intrecciata cat. y
woven leather nabuk
10 colori - colours

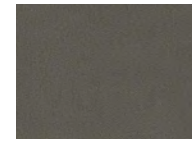

invecchiata cat. y
6 colori - colours



soft cat. y
14 colori - colours

Pelle Cashmere
Cashmere leather



bianco



grigio



nero

Bordura gros-grain - bordura in seta - filati
Grosgrain border - silk border - yarns



burro



perla



sahara

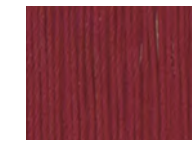

rubino



tempesta



navy



acciaio



nero

● escluso bordura in seta
except silk border

Provence coordinati letto
Bed linen Provence

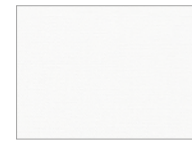

001 bianco



002 panna



008 polvere



004 tortora



006 roccia



007 grafite



003 ghiaccio

TAVOLINI
COFFEE TABLES



Creek, design Jean-Marie Massaud
pp. 10-23



Mondrian, design Jean-Marie Massaud
pp. 24-39



Henry, design Emmanuel Gallina
pp. 40-49



Bristol, design Jean-Marie Massaud
pp. 50-59



Tribeca, design Jean-Marie Massaud
pp. 60-69



Home Hotel, design Jean-Marie Massaud
pp. 70-81



Bigger, design Carlo Colombo
pp. 82-91



Soori, design Soo Chan
pp. 92-101



Ilda, design Jean-Marie Massaud
pp. 102-111



Flute, design Roberto Barbieri
pp. 112-121



Dama, design R&D Poliform
pp. 122-131



Baba, design Roberto Barbieri
pp. 132-141



Paris Seoul, design Jean-Marie Massaud
pp. 142-151



Sydney, design Jean-Marie Massaud
pp. 152-163



Tridente, design Emmanuel Gallina
pp. 164-173



Mad Coffee Table, design Marcel Wanders
pp. 174-183

POUF
POUFS



New York, design Jean-Marie Massaud
pp. 188-199



Henry, design Emmanuel Gallina
pp. 200-209



Play, design R&D Poliform
pp. 210-219



Onda, design R&D Poliform
pp. 220-229



Elise, design R&D Poliform
pp. 230-239



Gant, design R&D Poliform
pp. 240-249

TAPPETI
CARPETS



Frame, design R&D Poliform
pp. 254-259

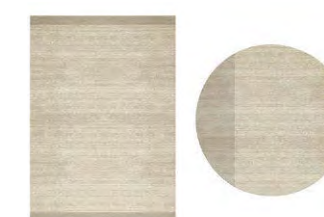

Plain, design R&D Poliform
pp. 260-265

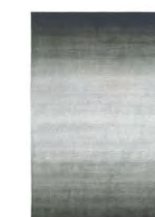

Soft, design R&D Poliform
pp. 266-271



Dama, design R&D Poliform
pp. 272-277

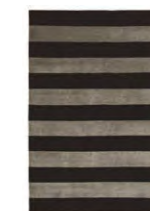

Stripes, design R&D Poliform
pp. 278-283

Poliform Spa
via Montesanto 28
Casella postale n. 1
22044 Inverigo (CO) Italy
t +39 031 6951
f +39 031 699444
info@poliform.it
poliform.it



2018 Adi Compasso D'oro
Career Award

Poliform realizza tutte le sue collezioni in Italia usando componenti e materie prime selezionate.

All the Poliform collections are manufactured 100% in Italy using top-class components and materials.

Poliform si riserva il diritto di apportare, senza preavviso, ogni modifica mirata al miglioramento funzionale e qualitativo dei propri prodotti. Testi e disegni presenti in questo stampato hanno scopo divulgativo: per ogni aspetto tecnico e dimensionale fare riferimento ai listini aziendali e relativi aggiornamenti. I campioni di colori e materiali hanno valore indicativo.

Poliform reserves the rights at all time to apply modifications for the functional or qualitative improvement of its products. Texts and drawings present in this brochure have a divulgative purpose: for every technical and dimensional aspect please refer to the company's price lists and their relative updatings. The colour and material samples have an indicative value.

Creative Direction
Apartamento Studios

Graphic Design
Apartamento Studios

Interiors Photography
Federico Cedrone, Omar Sartor

Still Life Photography
Silvia Orlandi

Interiors Styling
Poliform Lab

1st edition April 2019
cod. 108/R1/2019



TWO THOUSAND NINETEEN